



---

## System Installation Guide



*UTSCI System Setup and Operation*

---

---

---

---

## ***The Utah Scientific System Installation Guide***

- Document Number: 82101-0066
- Document Version: 8.0
- Date: March 7, 2012
- Printed in U.S.A.

### ***Copyrights and Trademarks***

© 2012 Utah Scientific, Inc., All rights reserved. Any use or reproduction of this guide's contents without the prior written consent of Utah Scientific, Inc. is strictly prohibited.

- SIG is a trademark of Utah Scientific, Inc.
- Windows references (all versions) are registered trademarks of Microsoft Corporation.
- All other product names and any registered or unregistered trademarks mentioned in this guide are used for identification purposes only and remain the exclusive property of their respective owners.

### ***Notice***

Information contained in this guide is subject to change without notice or obligation. While every effort has been made to ensure that the information is accurate as of the publication date, Utah Scientific, Inc. assumes no liability for errors or omissions. In addition, Utah Scientific, Inc. assumes no responsibility for damages resulting from the use of this guide.

### ***FCC Compliance (USA) and Digital Equipment Compliance (Canada)***

This equipment has been tested and found to comply with the limits for a Class A, digital device, pursuant to Part 15, Subpart B of the FCC Rules and the Canadian EMC Requirement (ICES-003). These limits are designed to provide reasonable protection against harmful interference when the equipment is operated in a commercial environment. This equipment generates, uses, and can radiate radio frequency energy and, if not installed and used in accordance with the instruction manual, may cause harmful interference to radio communications. Operation of this equipment in a residential area is likely to cause harmful interference, in which case, the user will be required to correct the interference at their own expense. Shielded cables must be used to ensure compliance with the FCC Class A limits.

---

---

## ***Declaration of Conformity***

### **Utah Scientific, Inc.**

4750 Wiley Post Way, Suite 150  
Salt Lake City, Utah 84116-2878 U.S.A.

We declare our sole responsibility that the Utah-400 Digital Routing Switcher is in conforMan V2ce with the following standards:

### **Emission**

- EN55022:1994+A1&A2

### **Immunity**

- EN55024:1998
- EN61000-3-2
- EN61000-3-3

### **Safety**

- IEC 60950-1:2001 /EN 60950-1:2001

Following the provisions of the Directive(s) of the Council of the European Union:

- EMC Directive 89/336/EED
- Low Voltage Electrical Directive 72/23/EEC

Utah Scientific, Inc. hereby declares that the product specified above conforms to the above Directive(s) and Standard(s).



---

---

## ***Important Safeguards and Notices***

This section provides important safety guidelines for the Operator and Service Personnel. Specific warnings and cautions are found throughout the guide where they apply, but may not appear here. Please read and follow the important safety information, specifically those instructions related to risk of fire, electric shock, or injury to persons.

### **Safety Symbols**



- Hazardous Voltage symbol



- Caution symbol. The product is marked with this symbol when it is necessary to refer to the manual to prevent damage to the product.

### **Warnings**

Please observe the following important warnings:



- Any instructions in this guide that require opening the chassis, changing a power supply, or removing a board, should be performed by qualified personnel only. To reduce the risk of electric shock, do not perform any service unless you are qualified to do so.
- Heed all warnings on the unit and in the operating instructions.
- Do not use this product in or near water. Disconnect AC power before installing any options or servicing the unit unless instructed to do so by this manual.
- This product is grounded through the power cord ground conductor. To avoid electric shock, plug the power cord into a properly wired receptacle before connecting the product inputs or outputs.
- Route power cords and other cables so they won't be damaged.
- The AC receptacle (socket) should be located near the equipment and be easily accessible.
- Disconnect power before cleaning. Do not use any liquid or aerosol cleaner - use only a damp cloth.



- Dangerous voltages exist at several points in this product. To avoid personal injury, do not touch exposed conductors and components while power is on. Do not insert anything into either of the systems two-power supply cavities with power connected.
- Do not wear hand jewelry or watches when troubleshooting high current circuits, such as power supplies. During installation, do not use the door handles or front panels to lift the equipment as they may open abruptly and injure you.
- To avoid fire hazard when replacing fuses, use only the specified correct type, voltage and current rating as referenced in the appropriate parts list for this product. Always refer fuse replacement to qualified service personnel.
- Have qualified personnel perform safety checks after any service.

#### **Cautions**

Please observe the following important cautions:



- When installing this equipment do not install power cords to building surfaces. To prevent damage when replacing fuses, locate and correct the problem that caused the fuse to blow, before reconnecting power.
- Use only specified replacement parts

#### **Notices**

Please observe the following important notes:



- When the adjacent symbol is indicated on the chassis, please refer to the manual for additional information.
- For the HD-2020 Chassis and Master Control Panel, refer to “Connecting and Disconnecting Power” - Chapter 2 (Hardware Installation).

---

---

## *Company Information*

### **Utah Scientific, Incorporated**

**4750 Wiley Post Way, Suite 150  
Salt Lake City, Utah 84116-2878 U.S.A.**

- Telephone: +1 (801) 575-8801
- FAX: +1 (801) 537-3098
- Technical Services (voice): +1 (800) 447-7204
- Technical Services (FAX): +1 (801) 537-3069
- E-Mail -General Information: [info@utsci.com](mailto:info@utsci.com)
- E-Mail -Technical Services: [service@utsci.com](mailto:service@utsci.com)
- World Wide Web: <http://www.utahscientific.com>
- **After Hours Emergency:** +1 (800) 447-7204. Follow the menu instructions for Emergency Service.

---

---

## ***Warranty Policies***

### **Hardware Warranty**

Utah Scientific, Inc. warrants to the original purchaser that the Utah Scientific hardware is free from defects in materials and workmanship and will perform substantially in accordance with the accompanying written materials under normal use and service for a period of ten (10) years from the date of shipment. Any implied warranties on hardware are limited to ten (10) years. Some states/jurisdictions do not allow limitations on duration of an implied warranty, so the above limitation may not apply to certain specific purchasers.

### **Software Warranty**

Utah Scientific warrants that the software will perform substantially in accordance with the accompanying written materials for a period of one (1) year from the date of shipment.

### **Customer Remedies**

For the first one (1) year after purchase of the software and the first ten (10) years after the date of purchase of the hardware, Utah Scientific's and its suppliers' entire liability and purchaser's exclusive remedy shall be, at Utah Scientific's option, either:

- Return of the price paid, or
- Repair or replacement of the software or hardware that does not meet the above warranties and is returned to Utah Scientific under the returned materials authorization (RMA) process with freight and forwarding charges paid.

After the initial warranty periods, purchaser's exclusive remedy is the repair or replacement of the hardware upon payment of a fixed fee to cover handling and service costs based on Utah Scientific's then-current price schedule. The above warranties are void if failure of the software or hardware has resulted from an accident, abuse, or misapplication. Any replacement software or hardware will be warranted for the remainder of the original warranty period or thirty (30) days, whichever is longer.

***No other warranties.*** To the maximum extent permitted by applicable law, Utah Scientific and its suppliers disclaim all other warranties, either express or implied, including, but not limited to implied warranties of merchantability and fitness for a particular purpose, with regard to the software, the accompanying written materials, and any accompanying hardware. This limited warranty gives the purchaser specific legal rights. These rights may vary in certain states/jurisdictions.

***No liability for consequential damages.*** To the maximum extent permitted by applicable law, in no event shall Utah Scientific or its suppliers be liable for any damages whatsoever (including without limitation, damages for loss of business profits, business interruption, loss of business information, or any other pecuniary loss) arising out of the use of or inability to use

---

---

Utah Scientific products, even if Utah Scientific has been advised of the possibility of such damages. Because some states/jurisdictions do not allow the exclusion or limitation of liability for consequential or incidental damages, the above limitation may not apply in those circumstances.



---

*System Installation Guide*

**1 - Program Installation**

Introduction .....	1-1
Batch File Selection (Utility Help List) The Software Installation's Purpose .....	1-2
Basic Descriptions of the UTSCI Program Components .....	1-2
The products supported in this release include: .....	1-3
System Hardware Requirements .....	1-4
General Router/Switcher Terminology .....	1-5
Routing Switcher Basics .....	1-6
Switching Matrix .....	1-6
Signal Levels .....	1-8
UTSCI Install Utility .....	1-10
Using the UTSCI Install Utility .....	1-10
The Installation Routine - UTSCI CD .....	1-11
Adding Export Directory .....	1-18
Adding NFS License Files Manually' .....	1-21
Encoding Retrieval Using the New Utility .....	1-28
New Systems with the UTSCI Install Utility Already Installed .....	1-32
'Install Application Software on PC' .....	1-38
Remaining Utilities and Help Functions .....	1-44
Batch File Selection (Utility Help List) .....	1-45
Net Verification .....	1-45
Burn Software .....	1-45
Burn Firmware .....	1-45
Burn SW / FW Set .....	1-45
Burn Encoding .....	1-45
Get Encoding .....	1-45
Save Encoding .....	1-46
Burn Logos .....	1-46
Get System Info .....	1-46
Get Version .....	1-46
Get Revision .....	1-46
NFS Mount .....	1-46
Telnet Connection .....	1-46
Router Save .....	1-47
Edit Encoding .....	1-47
Router Load .....	1-47
Tieline Display .....	1-47

---

Tieline Clear .....	1-47
Locks Display .....	1-47
Locks Clear .....	1-47
Configure Script Addresses .....	1-47
Chassis Operations .....	1-48
Save System Info .....	1-48
Updating Existing System Software Folders .....	1-49
What's Next? .....	1-52

## 2 - Additional Setup

Device Software Lookup .....	2-1
Locating IP Addresses .....	2-2
Device IP Address Identification .....	2-2
PC Address Identification .....	2-4
What's Next? .....	2-4

## 3 - System Configuration

Introduction .....	3-1
U-NET Interconnection .....	3-2
Panel Support on the U-NET Ports .....	3-2
U-NET Cable Requirement .....	3-2
U-NET Cable Topologies .....	3-3
A basic daisy chain configuration .....	3-3
A daisy chain with RJ-45 T connectors .....	3-4
Star configurations .....	3-5
Combining daisy chain and star topologies in a configuration .....	3-5
Extending a U-NET Configuration with U-NET Hubs .....	3-6
Using one U-NET Hub on an System Controller's U-NET port .....	3-7
MX-Bus Interconnection .....	3-8
System Controller (SC-4) connections .....	3-8
Cable requirements .....	3-8
Ethernet Interconnection .....	3-10
Options and Requirements .....	3-10
Ethernet Cabling Configurations .....	3-10
Standalone configurations .....	3-10
Network Configurations .....	3-13

## 4 - Additional Update and Installation

Remaining Utilities and Help Functions .....	4-1
Batch File Selection (Utility Help List) .....	4-3
Net Verification .....	4-3
Burn Software .....	4-3
Burn Firmware .....	4-3
Burn SW / FW Set .....	4-3
Burn Encoding .....	4-3
Get Encoding .....	4-3
Save Encoding .....	4-4
Burn Logos .....	4-4
Get System Info .....	4-4
Get Version .....	4-4
Get Revision .....	4-4
NFS Mount .....	4-4
Telnet Connection .....	4-4
Router Save .....	4-5
Edit Encoding .....	4-5
Router Load .....	4-5
Tieline Display .....	4-5
Tieline Clear .....	4-5
Locks Display .....	4-5
Locks Clear .....	4-5
Configure Script Addresses .....	4-5
Chassis Operations .....	4-6
Save System Info .....	4-6
Updating Existing System Software Folders .....	4-7
New Systems with the UTSCI Install Utility Already Installed .....	4-10
Upgrading Device Software and Firmware Using the Utility .....	4-16
Device Type FW Version .....	4-16
Checking Firmware Revisions Using the New Utility .....	4-17
Upgrading the Device Firmware/Software Using the New Utility .....	4-23

---

---

## 5 - The Utah Scientific SYSLOG Program

Installing the System Logging Application .....	5-2
Running the Application .....	5-3
System Logging Menu .....	5-3
Keyboard Control Commands .....	5-3
Default Log Server Name and Location .....	5-5
Customizing Log Server Name .....	5-6
Logging Results .....	5-7
Parsing the data from the logs .....	5-8
Parsing (filtering) the log using key words .....	5-8
Master Control Keywords .....	5-11
SC4/SC400/SCX400 Router Controller Keywords .....	5-13
Usage Overview .....	5-13
TAS Protocol Notes (Automation) .....	5-14
Log Analyzer Application .....	5-17
Launching the Log Analyzer Application .....	5-17
Using the Application .....	5-17
Example of Problem with Two Buttons Pressed Simultaneously .....	5-20
Operator presses 2 buttons at the same time .....	5-20
Example of Auto Take Being Pressed .....	5-25
Automation Company Details for 2020/400 .....	5-28
AUTOMATION COMPANY DETAILS for SC-4/SC-400/SCX-400 .....	5-29
DEBUG2020 UTILITY .....	5-29

## 6 - MC-2020/MC-400 Logo Generation/ Program Installation

Installation of the Microsoft™ .net Framework .....	6-2
Installing the 2020 Logo Conversion Application .....	6-3
Creating a USI Format Logo File .....	6-3
Installing a Logo into a MC-2020 Master Control Channel .....	6-6
Displaying a logo you have installed into the MC-2020 .....	6-7
Clearing Existing Logos .....	6-9

## A - Software and Program Removal

Overview .....	A-1
Objective .....	A-2
Directories .....	A-2
Utilities .....	A-2
Step One - Program Removal .....	A-2
Step Two - Directory Removal .....	A-5
Step Three - Java™ Removal (Optional) .....	A-6

## B - Batchfile Description Table

Introduction .....	B-1
C:USI Batch File Definitions .....	B-2
SC4/SC400/SCVX400 .....	B-2
Encode Folder .....	B-2
Updates Folder .....	B-3
Encode Folder .....	B-4
Updates Folder .....	B-4
MCP-2020/MCP-40/MCP-400 Panels .....	B-6
Encode Folder .....	B-6
Updates Folder .....	B-6
ESI-2020 .....	B-7
Encode Folder .....	B-7
Updates Folder .....	B-8
MXLator .....	B-9
Encode Folder .....	B-9
Updates Folder .....	B-9

---

---

## C - Setting Panel ID's (Using the SC-4 Test Utility)

Introduction .....	C-1
Required Equipment .....	C-1
Procedure .....	C-1
SC-4 Test Utility Commands .....	C-2

## D - Diagnostic Port Quick Commands

Terminal Commands for the SC-4 and Master Control .....	D-2
SC4/SC400 Commands .....	D-2
Chassis Functions .....	D-2
SC-4 Functions .....	D-3
Router Functions .....	D-4
Miscellaneous Terminal Commands .....	D-4
MC-2020/MC-400 .....	D-5
Chassis Functions and Commands .....	D-5
MC-2020 and MC-400 Functions .....	D-6
Miscellaneous Terminal Commands .....	D-6
MCP-2020/MCP-400 .....	D-7
Miscellaneous Terminal Commands .....	D-7
Device Software Lookup .....	D-8
Locating the IP Address for Additional System Devices .....	D-10
Changing IP Addresses in System Devices .....	D-11

## E - A Discussion About Timing

Timing Sources into the MC-2020 .....	E-1
Using the Timing Utility .....	E-2
2020 Timing Utility DEFINITIONS: .....	E-2
Connecting Via Serial .....	E-3
Connecting Via Telnet .....	E-3
Using LCD on MCP-2020 Panel .....	E-3
Adjusting Timing .....	E-4
Timing for Systems Using SqueezeMAX .....	E-4
SD SqueezeMAX Timing Upstream .....	E-4
SD SqueezeMAX Timing Downstream .....	E-5
HD SqueezeMAX Downstream .....	E-5

## F - EAS Setup

MC-2020 EAS Upgrade .....	F-1
MACRO SETUP for TFT and DASDEC Models .....	F-5
Macro Setup for Sage Models .....	F-6
GPI (Sage setup only) .....	F-7
AES Input Port (for TFT, Sage and Dasdec TFT) .....	F-7
AES Audio Only Buttons (for TFT, Sage and Dasdec TFT) .....	F-8
Manual Configuration .....	F-8
Wiring diagram from Utah MC-2020 to Sage .....	F-11
Sample TFT Macro .....	F-12
Sample SAGE Macro and GPI Section Config .....	F-13
Sample EAS Auto Action .....	F-14
Sample Serial Port Setup for MC2020 Interface to TFT or Sage .....	F-15
Sample EAS Display Configuration for TFT .....	F-16
Sample EAS Display Configuration for Sage .....	F-18
MC-400 EAS Setup .....	F-20
EAS CONFIGURATION (set the following) .....	F-21
SERIAL PORT SETUP (set the following – see figure above) .....	F-22
EAS CRAWL AND NOTIFY (set the following – see figure above) .....	F-22
MACRO SETUP for TFT and DASDEC Models .....	F-24
MACRO SETUP for Sage Models .....	F-25
GPI (Sage setup only) .....	F-26
AES INPUT PORT (for TFT, Sage and Dasdec TFT) .....	F-27
AES AUDIO ONLY BUTTONS (for TFT, Sage and Dasdec TFT) .....	F-28
EAS CONFIGURATION (set the following) .....	F-29
EAS CRAWL AND NOTIFY (set the following – see figure above) .....	F-29
MACRO SETUP for DASDEC EAS Net .....	F-31
AES INPUT PORT for Dasdec - (setup in Audio source and btns) .....	F-32
AES AUDIO ONLY BUTTONS (for TFT, Sage and Dasdec TFT).....	F-32
MANUAL CONFIGURATION .....	F-33
TO ENABLE MANUAL ALERT and trigger from MCP-400 PANEL .....	F-34
TFT EAS SETUP FOR MC400 .....	F-34
SAGE EAS SETUP FOR MC400 .....	F-34
Wiring diagram from Utah Masters to Sage .....	F-35
Config Section Requirements Summary .....	F-35
Sample TFT Macro .....	F-36
Sample SAGE Macro and GPI Section Config .....	F-37
Sample EAS Auto Action and Operation Mode .....	F-38
Sample Serial Port Setup for MC400 Interface to TFT or Sage .....	F-39
Sample EAS Display Configuration for TFT .....	F-39

---

---

Sample EAS Display Configuration for Sage .....	F-41
---	------

## **G - UCP Version Upgrade Procedure**

Checking the Current Version - UCP Panel .....	G-1
Upgrade Procedure .....	G-2
Upgrade Procedure for UCP-64 Style Panels with the UNIC803 Chip Set .....	G-2





# Program Installation

## Introduction

The System Installation Guide has been developed to walk new and upgrading users through the Utah Scientific system software installation process. Users installing UTSCI software to their systems for the first time will be directed to the necessary steps for complete file load, while upgrading users will have access to only the portions of the installation that are applicable to them.

This section contains the following:

- The Software Installation's Purpose
- Supported Products in this Release
- System Hardware Requirements
- General Router/Switcher Terminology
- The Installation Routine
- Encoding Retrieval Using the New Utility
- Install Application Software on PC
- Remaining Utilities and Help Functions

## **Batch File Selection (Utility Help List) The Software Installation's Purpose**

The Utah Scientific System Software Installation places all necessary interface elements within your PC's operating environment, along with the needed server and 'background/server processes' that make router and switcher communication possible.

### ***Basic Descriptions of the UTSCI Program Components***

**TeraTerm** – This is a terminal program that is used for connecting via telnet or serial, to the diagnostic ports on the equipment listed on page 1-3. It can also be used for running log files.

**NFS Server** – This is a software server that is used to mount specific drives and folders to file storage locations, then used to program those files into these specific devices listed on page 1-3.

**U-CON V4** (Utah Configurator) – This program is used specifically to program the SC4 and SC400 control cards with router matrix tables, sources, and destinations. It is also used to program the different types of control panels connected to these controllers.

**rMan V2** (Router Management) – This application is a tool used for viewing real time switching of the router matrix, using either a graphical view of colored connections or a view by device names. This also displays the matrix table with physical cross point numbers and their assigned index/device number. Various alarm conditions such as tielines, controller fan and power supplies and loss of signal are also displayed in this application.



The products supported in this release include:

---

## The products supported in this release include:

- Master Control System Release
  - MC-4000 Master Control Chassis
  - MC-400 Master Control Card
  - MCP-400 Master Control Panel
  - MC-40 Master Control Card
  - MCP-40 Master Control Panel
  - SD-2020 Master Control Chassis
  - MCP-2020 Master Control Panel
  - HD-2020 Master Control Chassis
  - ESI-2020 Machine Control Chassis
  - Master Control Chassis Configuration Application
  - Master Control Panel Configuration Application
- Router Control System Release
  - SCX-400 Router Controller
  - UCI-400 Router Control Interface Bridge
  - UCON-V4 Utah Scientific System Configuration Application
  - RMAN-V2 Utah Scientific Router Management Application
  - MX-LATOR Router Control Interface/Bridge
  - SC-4 Router Controller
  - SC-400 Router Controller
  - U-CON - Utah Scientific System Configuration Application
  - rMan - Utah Scientific Router Management Application
  - UCP Panels

## System Hardware Requirements

Proper installation of the UTSCI CD software components will involve the following:

Item	Minimum	Recommended
Processor	Intel Pentium II	Intel Pentium IV
Operating System	Windows 2000	Windows XP
Memory	128 MB Ram	512 MB Ram
Hard Disk	384 MB Free Space Including Swap File	--
Monitor	17" 1024x768 Color Monitor	--
Video Card	1024x768 capable, 8 MB of RAM	==
CD-ROM	Any	Any
Ethernet Adapter	10 Base T	--
Serial Port	Any	Any



## General Router/Switcher Terminology

In its basic form, the Utah Scientific Router/Switcher Topology contains the following:

- Controllers
- Control Panels
- Routers
- Configuration PC
- MC-2020

The SC-4 and UT-400 are connected via the MX-Bus, the Configuration PC communicates via Ethernet, and the control panels (and MC-2020) use U-NET and/or Ethernet for SC-4 communication.

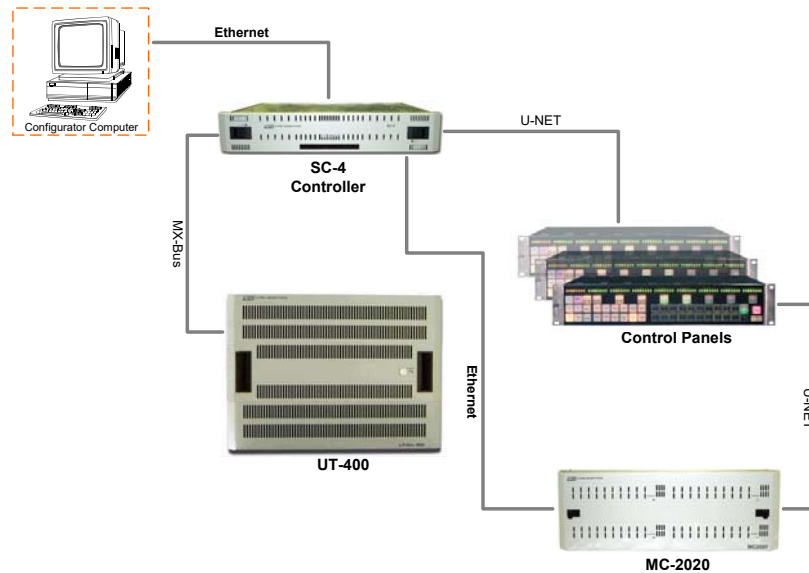

Figure 1-1. Basic System Layout

Systems will vary with regard to number, and exact components needed. Please see Section 2 for more specific connection detail.

### ***Routing Switcher Basics***

A routing switcher is a specialized form of broadcast equipment that allows the user to connect large numbers of source and destination devices together electronically – without patching or running cables across floors and without significant signal loss.

The routing switcher solves connectivity problems and increases signal qualities in a wide variety of applications. The technologies of routing switchers now include the standard analog, digital video, digital audio, and increasingly the high definition formats.

The routing switcher provides the user with the following advantages:

- Many signal levels (determined by the matrix size) may be switched simultaneously.
  - A simple route connects (switches) one signal level from one source (for example a VTR) to one destination (a monitor).
  - A complex route would connect multiple signal levels from one source to multiple destinations, including tie lines. For example, a satellite feed to a group of VTRs and monitors.
- Audio and video signal levels can be switched in groups (all follow takes) or individually (breakaway takes). Any input can be switched to any output, limited only by the matrix size.
- The Routing Switcher may be controlled manually via control panels, or with computer controlled automation.

### ***Switching Matrix***

A switching matrix is the internal array of inputs, crosspoints and outputs that allow a routing switcher to perform the task of routing signals from sources to destinations. The figure below illustrates a simple 10 X 10 switching matrix – with 10 Inputs and 10 Outputs.



Note the following points regarding the illustration:

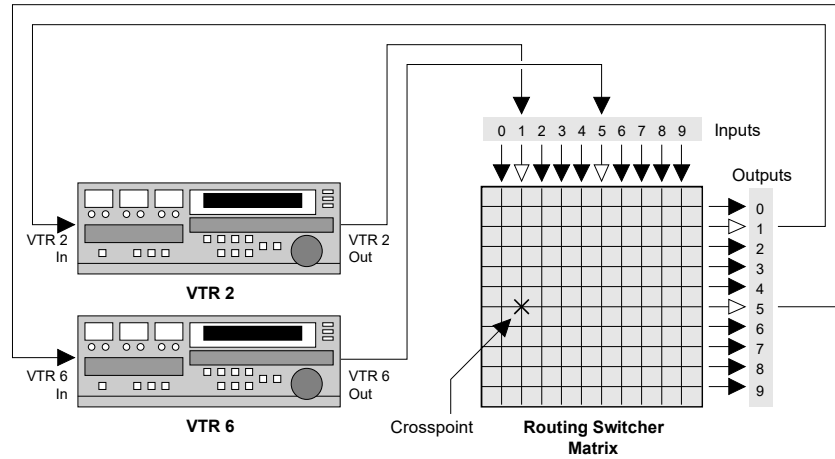

- Each VTR is fully connected to the matrix – all audio/video inputs and outputs.
- A cross-point (represented by an **X**) is the internal electronic connection of the input to the output – either audio or video.
- When the cross-point is turned "**ON**" the connection is made between the source and destination. The action of turning the cross-point on is known as making a "**Take**".
- When an entire audio/video array is connected in this manner, from all of the devices in your facility, you have full routing flexibility.
- Without re-cabling or re-patching, a device can play back one moment (as a source) and record the next moment (as a destination).

### Signal Levels

A "signal level" represents one of many specific types of audio or video elements that a routing switcher is capable of handling. The typical signals capable of being switched are:

- Analog Video
- Analog Audio (stereo with left and right channels).
- Digital Video
- Digital Audio (dual channel – stereo pair)
- High Definition Video.

Some systems may be configured with one signal level, while others may be configured with multiple signal levels.

While the diagram in the previous section shows only one signal level, a multi-signal level system is capable of routing any combination up to 16 levels – each with its own matrix and cross-points.

The figure below illustrates **eight signal levels** in a 10 X 10 matrix system.

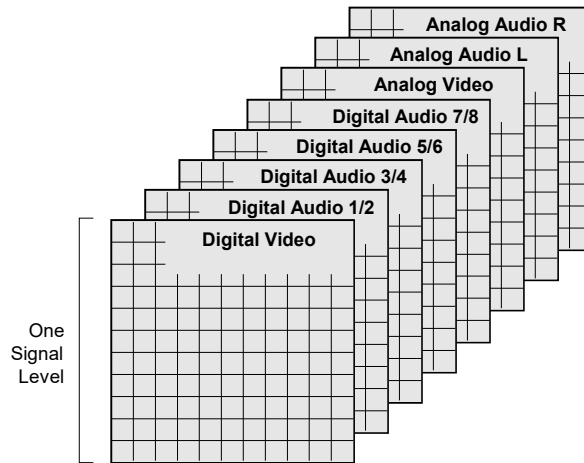

Signal routers are typically much larger than a 10 X 10 matrix, depending on user needs. Each signal level may also have different sizes of matrices and do not all need to be the same size.





## UTSCI Install Utility

Utah Scientific's graphical installation interface for system setup is designed to streamline most of the previous setup and maintenance functions. Using one simple dialog, you can perform software installation and system upgrades for any component in your operation.

## Using the UTSCI Install Utility

If you are using a new system purchased after 3/15/2009 with an SC4/SC400/SC400X and have the Utah System CD v3.xx with all of the software already loaded on a computer, including a shortcut to this Utility, then launch the Utsci Install Utility application and skip to the section below called "New systems with UTSCI Install Utility already installed".

If you are using a new system purchased after 3/15/2009 with an SC4/SC400/SC400X and have the current Utah System CD v3.xx but DO NOT have all of the software loaded on a computer, including a shortcut to this Utility, then skip to step 3 below and begin there.

If you are an existing customer then you should already be familiar with the script files that are used from the c:\usi folder. In this case you will need to proceed in following all of the steps below.

To use the "Utsci Installation Utility" you must upgrade all system software folders using system cd version 3.41 or newer, which will replace the old platform batch file and program functionalities in the c:\usi environment prior to this release. We recommend that you make a backup of the current usi folder of which steps are included in the following procedure. If you are using a system purchased after 3/15/2009 but have existing equipment prior to this and do not have a folder called c:\usi then skip to step 3 and begin there.



## The Installation Routine - UTSCI CD

This installation procedure places the necessary Utah Scientific software components on your system, or if applicable, updates the software you may have previously installed.

Any new or upgraded files will be placed in a new USI directory, where they will be called from during later installation sequences. The following procedure will ensure that all of the necessary files are properly installed.

1. Perform getencode.bat from each device folder in c:\usi encode folder and verify that the.conf file is updated. These config files will only be used for backup purposes if needed.

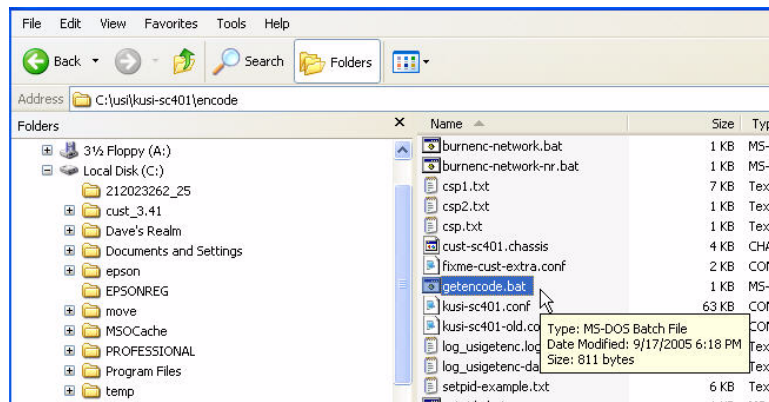

2. Change name of c:\usi folder to c:\backup usi.
3. Copy the new system cd to c:\ and open the pc prep folder.

#### 4. PC Prep Installation

The System Installation CD contains two folders and one table of contents file (text file). Double-click the '**pc-prep**' folder to access the PC Prep batch file. When the file is visible, double-click the **pc-prep** file to run the application. The following DOS window will briefly appear before the Tera Term utility is launched (next page).

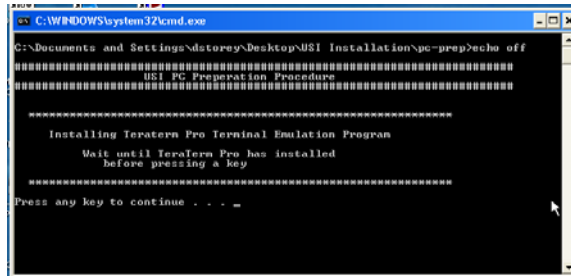

*The above DOS screen will remain active as a separate window in the background.*

The first dialog is the language confirmation. Click **Continue** to proceed.





The following dialog will appear:

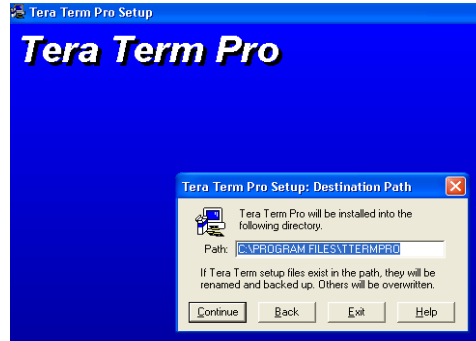

**Note:** *This installation will overwrite any previous versions of Tera Term you may have installed. If applicable, make sure the Tera Term application is closed.*

Click **Continue** to proceed.

One more dialog will appear, prompting you to confirm the default pathway for the directory installation.

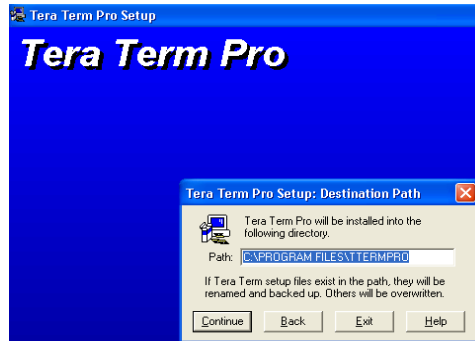

Click **Continue**.

At this point the installation will launch. This will only take a few seconds.

When the process is complete, the Tera Term Pro directory window will remain on your screen temporarily (A). It will eventually disappear, leaving a Tera Term 'finished' dialog (B).

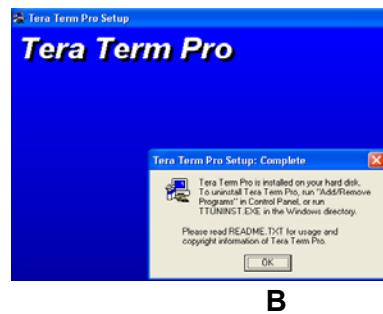
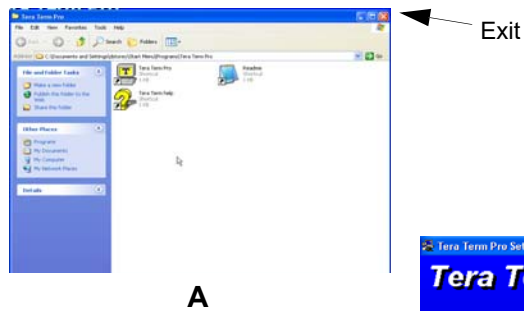

You can close the directory window (if you'd like) by clicking the *exit* box.



A DOS window will remain, prompting you to 'press any key' to continue.

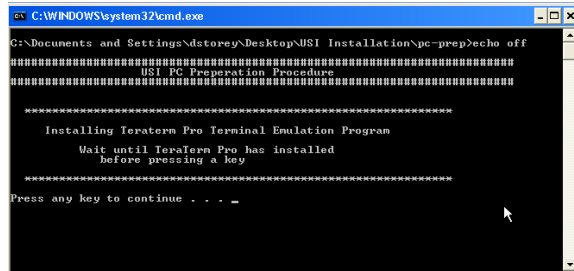

When you do this, a series of Labtam/ProNFS installation dialogs will appear, leading eventually to the following screen.

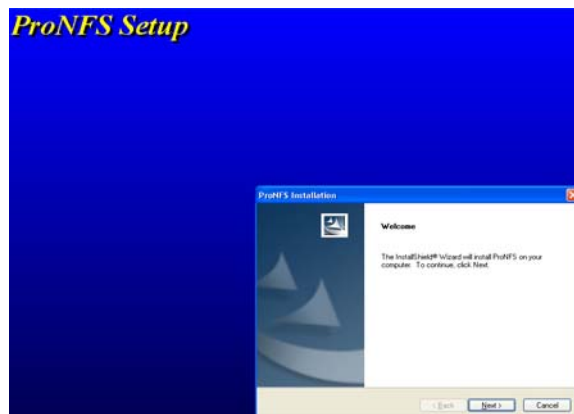

The 'ProNFS' installation wizard has now been launched. Press 'Next' to continue with the installation.

**Note:** *The DOS window remains active in the background.*

(Continued)

Accept all installation defaults as they appear in the following dialogs:

- Accept 'Typical' as your installation type -- as opposed to *Custom* or *Minimum*.
- Accept the *Default Destination Location* for the file load.
- Accept the default folder name - ProNFS vX.X.
- Accept any default of 'Demo' where it appears for *Name* or *Company*.

The ProNFS installation will now commence.

When the wizard completes its installation, click 'Finish' to wrap the installation.

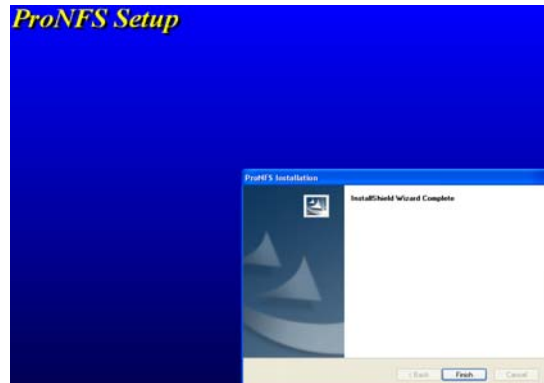

The DOS window will remain on your screen.

```
C:\WINDOWS\system32\cmd.exe
Wait until Teraterm Pro has installed
before pressing a key
-----
Press any key to continue . . .
copying Teraterm shortcut to desktop
Teraterm.lnk
1 file(s) copied.
1 file(s) copied.
1 file(s) copied.
Teraterm Pro Terminal Emulation Program Installation Complete
-----
Installing Pro NFS Server Program
Wait until PRO NFS has installed
before pressing a key
-----
Press any key to continue . . .
```

This may be in the background, behind other open windows. *Press any key* the number of times necessary to close this display.





The license files should have been installed during the NFS Server installation. If the license files were not installed, then the application will only run for 60 minutes.

To verify that they installed correctly, go to 'Start/Program Files/ProNFS Vx.x' in the lower left corner of the desktop. Click the application called 'NFS-Server'. When the program starts, click on the button called 'About' and the following window should appear.

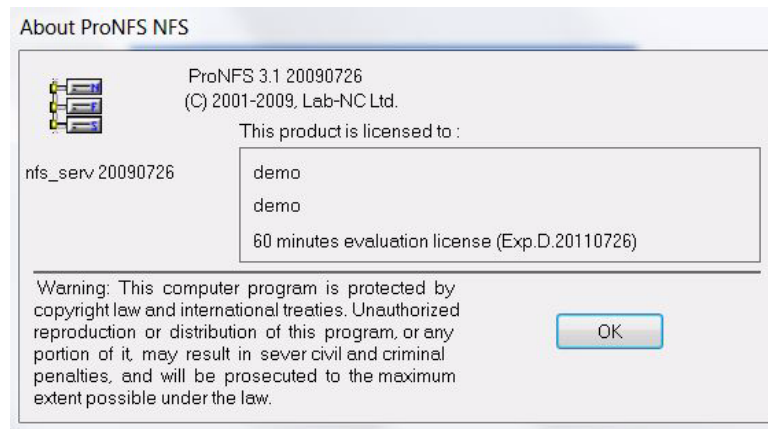

'If the license number says 'demo 60 minute evaluation' as seen here, or states that it is a demo or evaluation copy instead of showing a license number, then refer to the section below titled '**Adding NFS License Files Manually**'.

### ***Adding Export Directory***

With the correct license file running, the program should be running as normal. You may see the following window appear after the program is installed and launched for the first time, stating that the export directory is empty and if you wish to create it. Click 'Yes' if this comes up.



The following window will then appear with Export directories (empty) in the top pane and NFS User Access (empty) in the lower pane. Click on the 'Add directory...' button in the top right corner.

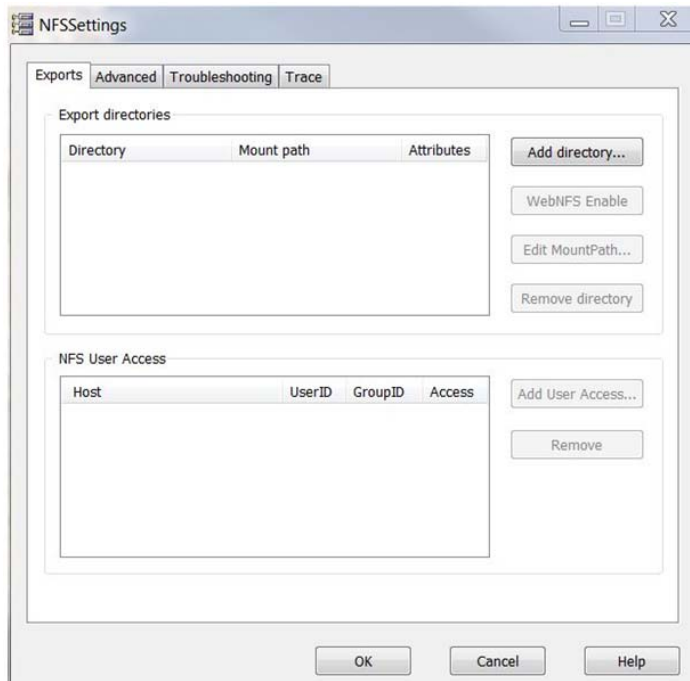



In the next window that appears, double click on the folder c\ and then scroll down the directories and find the usi folder. Double click on this usi folder and then click 'OK'. The following window will then appear with this export directory now showing in the pane.

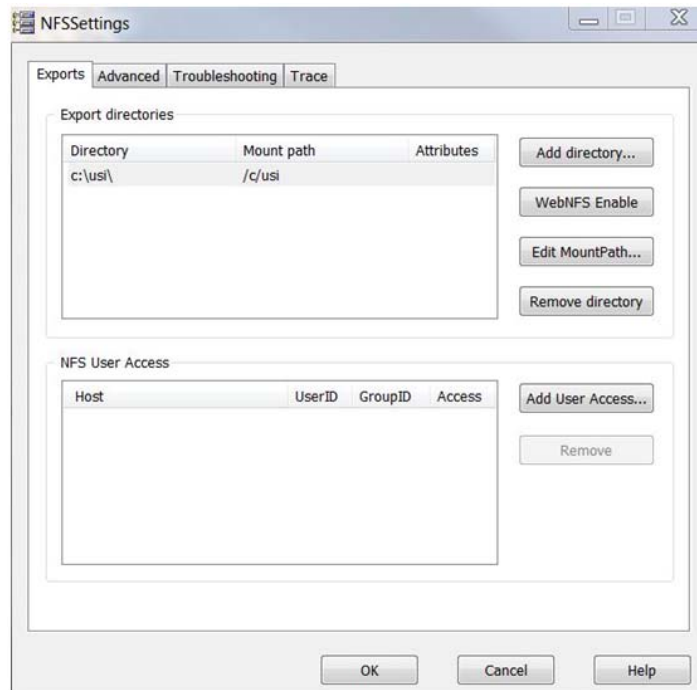

Next, click on the 'Add User Access' button to the right of the lower pane, and when the following window appears, uncheck the 'Read Only' box by clicking on it with the mouse. Then click the 'OK' button on this window.

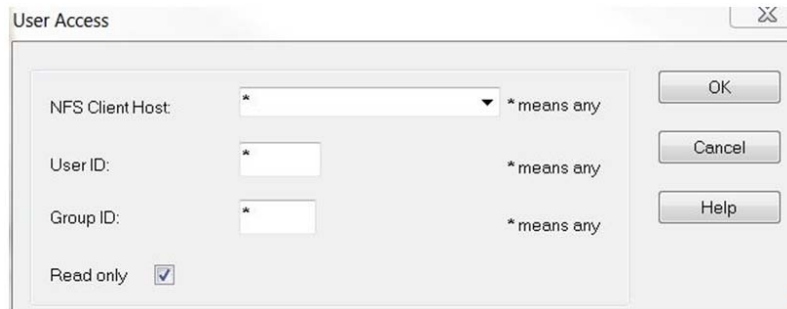

## Program Installation

---

This completes this step and you should now see the both panes as shown below. Click 'OK' on this screen and it will take you to the running NFS Server app. You may close the app when not in use. Otherwise, it must be running in order to send programming to devices via UCON.

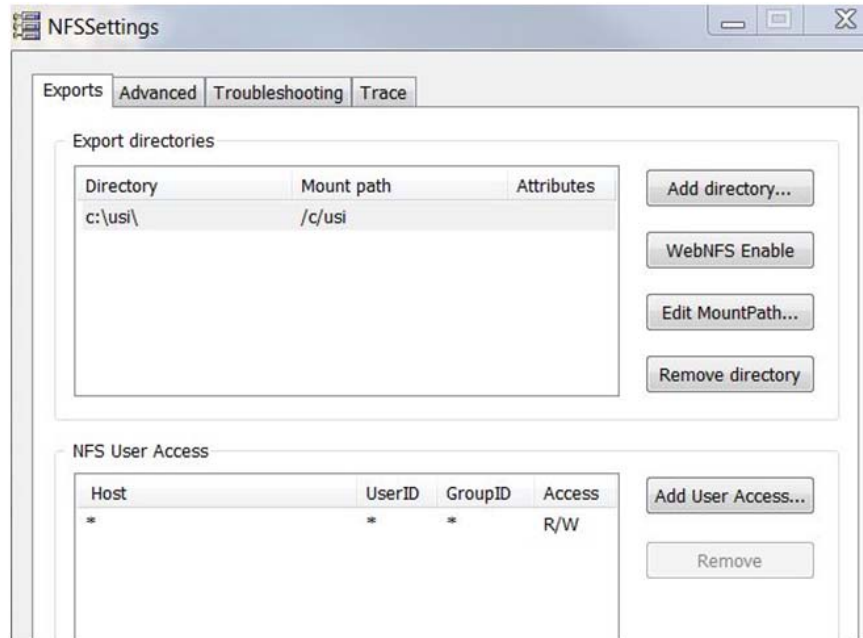



### ***Adding NFS License Files Manually***

Click 'Close' on the NFS screen and then click 'Yes' and NFS will shut down.

The reason NFS appeared with this evaluation window is because the license files that are required for the application to run were not updated properly in the program files directory, and will need to be manually added at this time. In order to do this, you will need to shut down the service or end the process, depending on the operating system, and then copy the new license files into the NFS directory by following the instructions below.

For Windows XP operating systems, you will need to end the running process found in the 'Task Manager'. To do this, hold down the buttons CTL, ALT and DEL at the same time and when the window opens, click on the task manager button and it will open. Click on the tab at the top of the task manager called 'Processes'.

## Program Installation

---

Locate the item in the list called 'nfs\_serv.exe'. Click on this item and then click the button called 'End Process' as seen in the figure below.

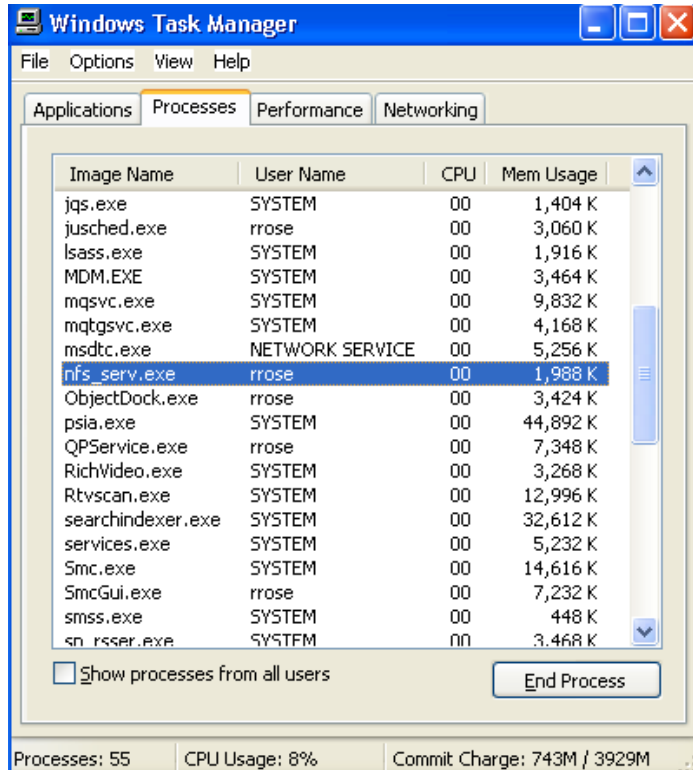

You must next add the license files to the NFS folder. Open the folder called `c:\usi\_install_3.x\pc-prep\misc`.

Locate the two files called 'disk1.id' and 'xwpdllid.dll'. (If these files are not in this folder, contact Utah Scientific Customer Service to receive these files). Block both of the files using the mouse and then right click on them and click copy. Go to 'C:\program files\labtam\pro nfs' and paste the files copied above into this folder. Click 'Yes to All' when prompted to overwrite the existing files.



For Windows 7 operating systems, you will need to stop the service found in the 'Task Manager'. To do this, hold down the buttons CTL, ALT and DEL at the same time and when the window opens, click on the task manager button and it will open. Click on the tab at the top of the task manager called 'Services'. Locate the item in the list called 'XwpXsetSrvProNFS'. Right click on this item and then click the item called 'Stop Service' as seen in the figure below.

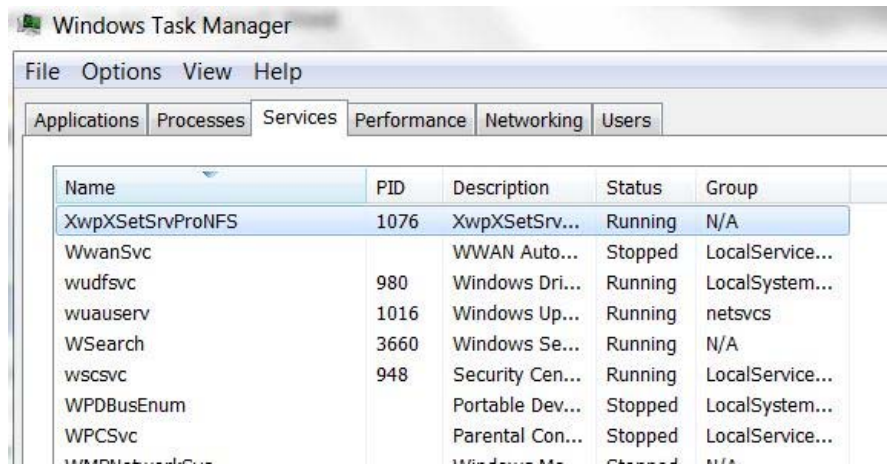

If this function does not allow you to stop the service, then you will either need an administrator to perform this for you or you can try the following.

## Program Installation

---

Go to 'Start' in the lower right of the computer and then click on 'Control Panel'. Then click on the 'Administrative Tools' button and find the item called 'Services' in the name list. Locate the item in the list called 'XwpXsetSrvProNFS' and then click the 'Stop the Service' item to the left of the name column as seen in the following figure.

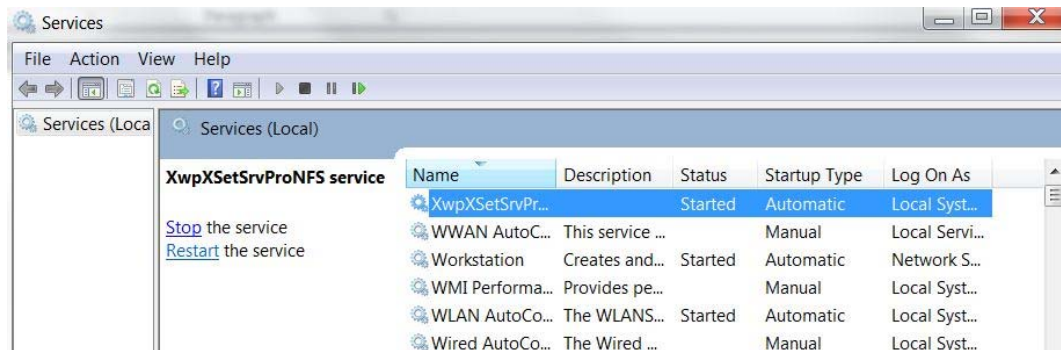

You must next add the license files to the NFS folder. Open the folder called `:\\usi_install_3.xx\\pc-prep\\misc`. Locate the two files called 'disk1.id' and 'xwpdllid.dll'. (If these files are not in this folder, contact Utah Scientific Customer Service to receive these files). Block both of the files using the mouse and then right click on them and click copy.





**Now go to 'C:\users\public\program files\lab-nc\pro nfs and paste the files copied above into this folder. Click 'Yes to All' when prompted to overwrite the existing files.**

Launch the NFS Server from the 'Start 'and 'Program Files' in the bottom left corner of the desktop. See figure below.

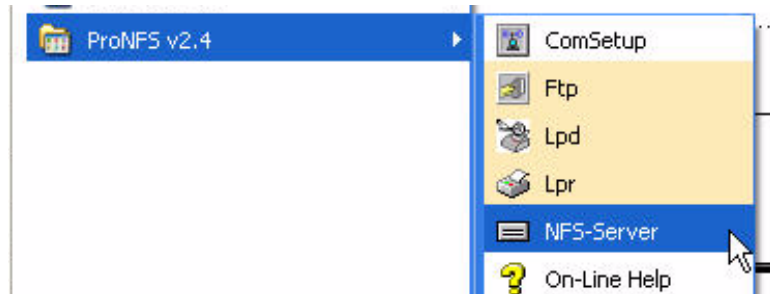

When NFS starts, click on the 'About' button and verify that there is a serial number in the window that appears and not a demo license.

The final step of the PC Prep batch file is the installation of the Utsci Install Utility. This will happen automatically and when complete it will place a shortcut on the desktop that looks like the following figure.



5. If the desktop is not where you would like the Utsci Install Utility shortcut then move it to a desired location and then launch the program.

- In the top selection window browse to the location of the install2020 folder found in step 3 above where the system cd was copied.

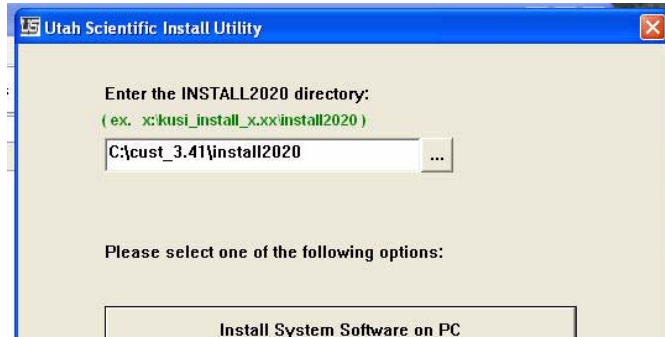

- A folder for each of the system devices must be added to the c:\usi directory. These folders will each have their own script files created during this process which will run various functions pertaining to each device. Begin by clicking on the 'Install System Software on PC' button on the main screen.

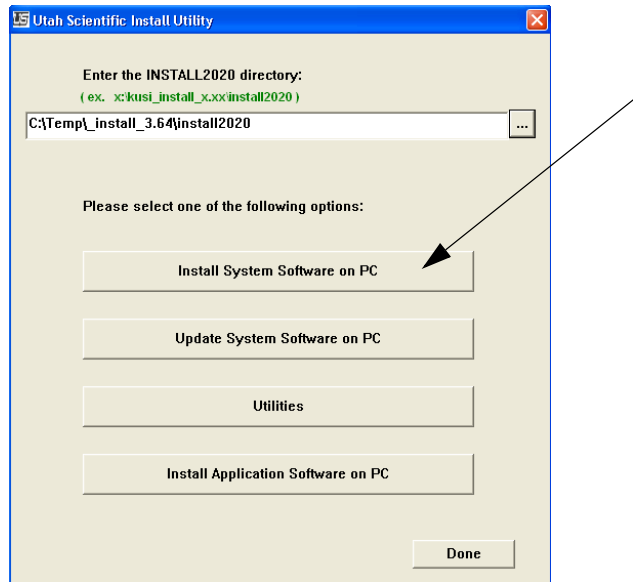



8. Enter the desired name or call letters for that new device folder.  
Note: this name will be attached as a prefix to the device type for that new folder.

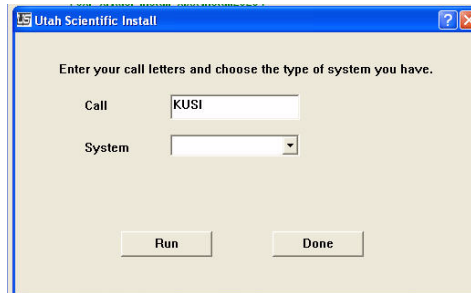

9. Drop down the System list and select one of the devices in your system such as the SC4 or SC400, then click 'Run'.

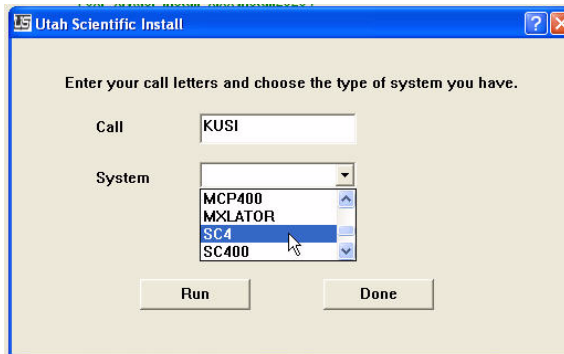

10. Go to Windows Explorer and locate the directory c:\usi and verify that all of the new devices, added from the steps above, appear in this folder.

The devices labeled CBSHD, ESI, HD, MCP and SD are all MC2020 products. All the other devices are self-descriptive of what they represent.

Note: This name will be the suffix of the name for that new folder and will add the number 01 to the end of the name. (i.e. -sc401) If you repeat this step using the same name and device it will add a 02 at the end of this next folder and so forth. Repeat this step for all physical devices in your system and click "Done" when finished.

## Encoding Retrieval Using the New Utility

Next you will need to retrieve the encode config file for each of the newly created device types using these steps. Pay attention to the message window at the bottom of the application as it will inform you of the current process as well as any errors.

1. Launch the Utsci Installation Utility and on the main screen click the Utilities button.

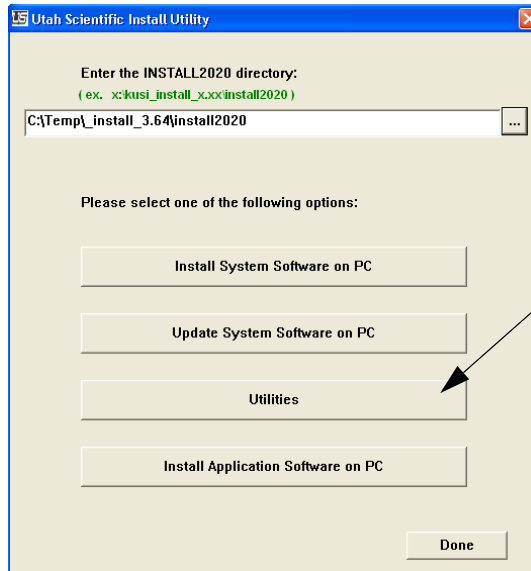

Note: if you do not already have the NFS Server running it will not allow you to proceed and you will get an error box indicating this.

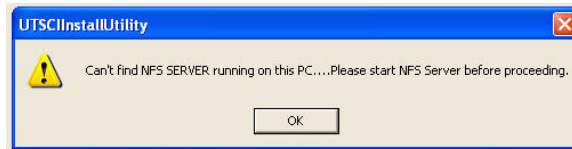



2. Drop down the selection list for the Device Type Filter and select each device type one by one such as the SC4.

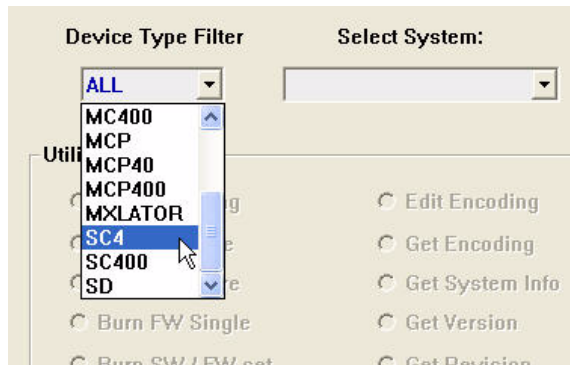

Keep in mind that the devices labeled CBSHD, ESI, HD, MCP and SD are all MC200 products. All the other devices are self descriptive of what they represent.

3. Drop down the selection list for the system you will be retrieving the encoding from.

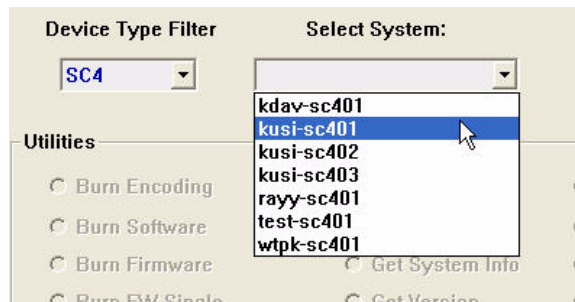

(Note: this will only display the system folders created above for that device type. I.e. – if you created a folder called KUSI and a device type for an SC4 then the list will only display a folder called kusi-sc401.)

4. All of the possible utilities for the selected device will be activated. You will need to enter the IP addresses for this device and the config pc you are using this application from.

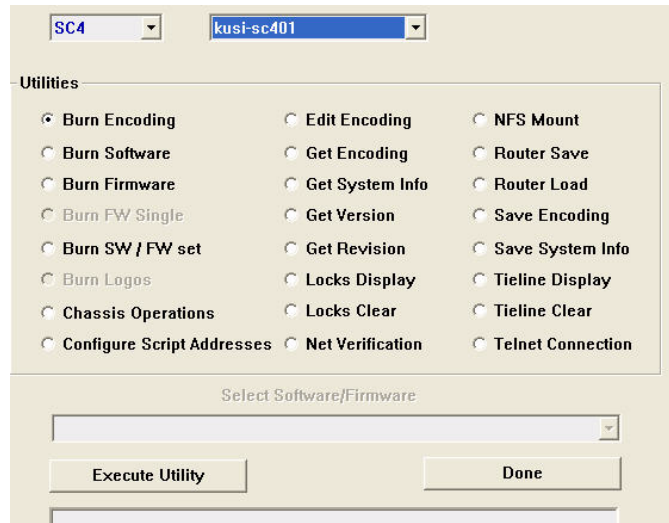

Unless you change the IP address in the device, this will be the only time you will need to set the addresses for the script files to function properly. Choose the “Configure Script Addresses” and then click on the “Execute Utility” button.

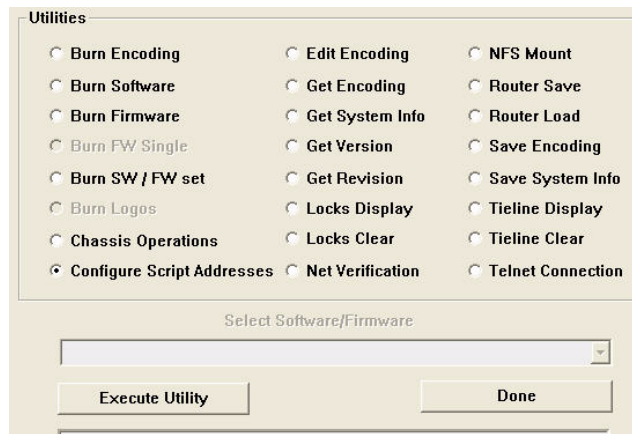

This will prompt you to enter the correct pc address first followed by the correct device address. It will retain this for all remaining utility functions.



5. Next choose the “Get Encoding” button and then click on the “Execute Utility” button.

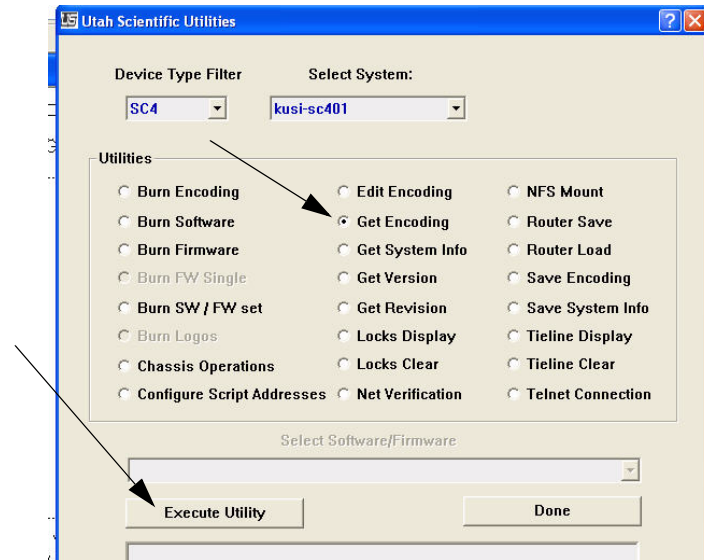

6. If you would like to view the config file retrieved in step 4 then change to the “Edit Encoding” utility and then click “Execute Utility”.

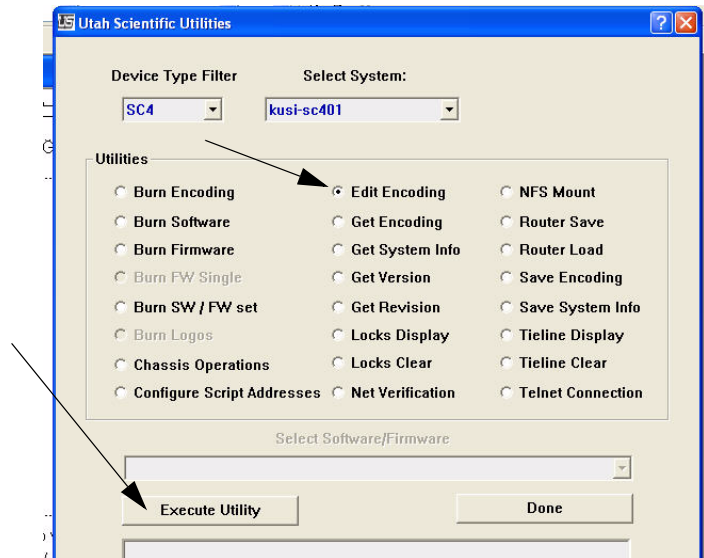

This will open the file for you to view and edit if needed.

Note: If a window opens prompting to choose what program to open it with, select Word Pad.

7. Perform steps 2-6 above for each device in your system.

### ***New Systems with the UTSCI Install Utility Already Installed***

Launch the application called "Utsci Install Utility". (Note: this application points to folders that were created in the c:\usi directory for each device on your system such as an SC4 controller and master control channel. It uses script files to look up critical information such as versions as well as retrieving and editing the current configuration files that are programmed into the device. It is also the tool for updating software and firmware into the device.)

Here are some bullets on utilizing this application.

(In the future) If you purchase a new device sometime after the initial install or wish to change the name of a folder in the c:\usi directory then refer to steps 7-9 in the section above titled "The Installation Routine - UTSCI CD".

**Note:** *If you wish to change the name after following these steps simply delete the original folder. You CANNOT just manually change the names of any folders found in c:\usi as the script files will no longer function.*

(In the future) If you receive a new system CD with the version newer than v3.41 then you will need to update your current folders following the steps found in the section of this guide called "Updating Existing System Software Folders."





To use any of the Utilities click on the “Utilities” button.

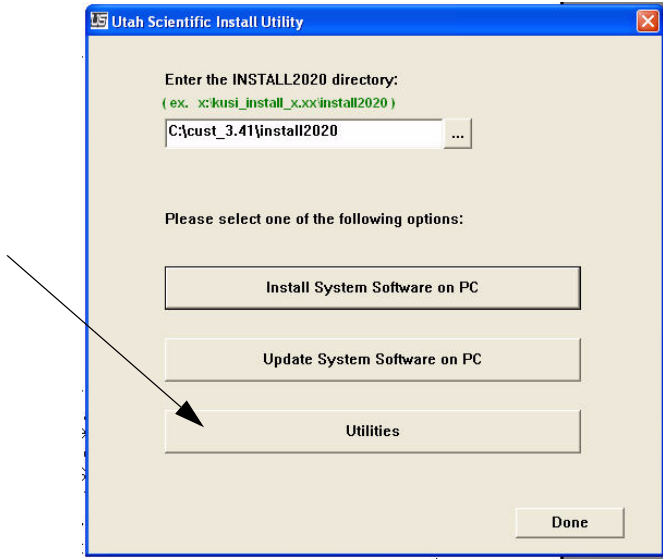

Note: If you do not already have the NFS Server running it will not allow you to proceed and you will get an error box indicating this.

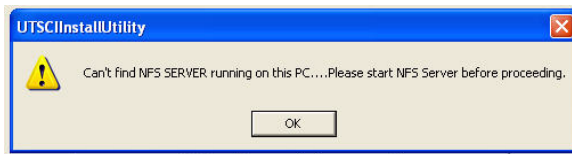

If the error does appear then go to your Utah Shortcuts folder and click on the NFS Server shortcut.

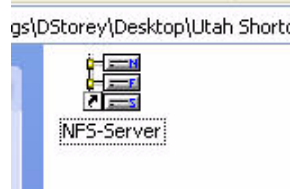

Then proceed to the next step.

Drop down the selection list for the Device Type Filter and select each device type one by one such as the SC4.

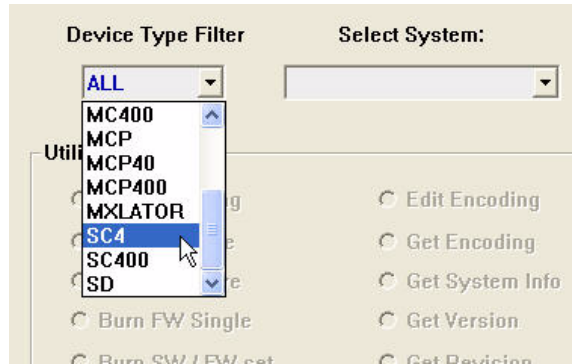

The devices labeled CBSHD, ESI, HD, MCP and SD are all MC2020 products. All the other devices are self descriptive of what they represent.

Drop down the selection list for the system you will be performing any utility on.

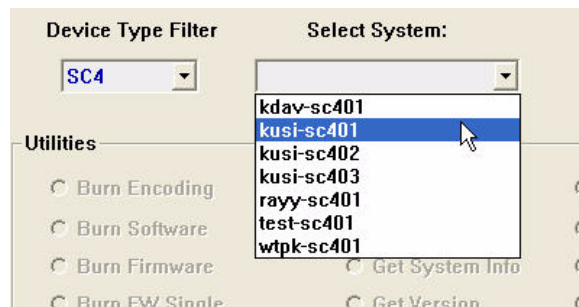

(Note: this will only display the system folders found in the c:\usi for that device type. I.e. – if a folder was created called KUSI and a device type for an SC4, then the list will only display a folder called kusi-sc401.)



At this point all of the possible utilities for the selected device will be activated.

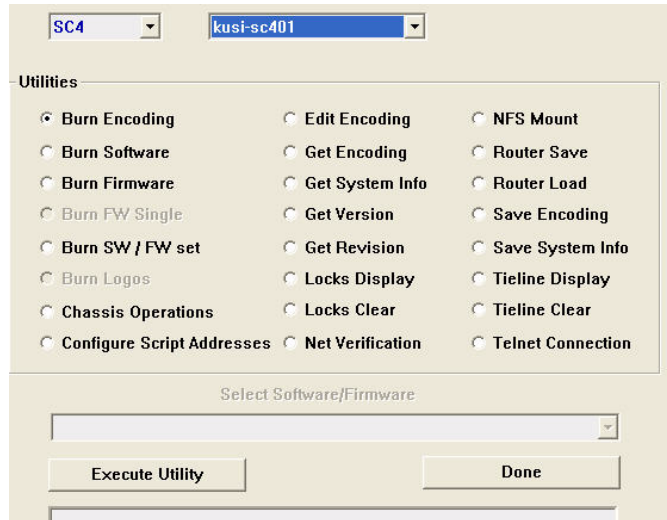

(Note: Unless Utah Scientific was supplied with IP addresses for each device then they would have been sent with default addresses and each utility will operate using those addresses and you can proceed along by skipping the next step.

IMPORTANT: If you wish to change each device address then you will need to run the Utility called “Chassis Operations” for each device and change the IP address as you are prompted to do so. Ignore any requests to change ID and customer name at this point by clicking no when asked.)

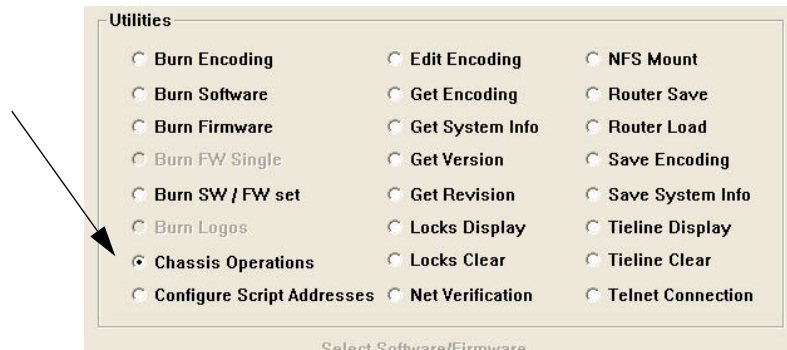

If you did make changes to the IP addresses in the previous step then you will need to enter the IP addresses for this device and the config pc into the script file location in this Install Utility application. Unless you change the IP address in the device. After this the Utility will remember the new IP address and this will be the only time you will need to set the addresses for the script files to function properly. Choose the “Configure Script Addresses” and then click on the “Execute Utility” button.

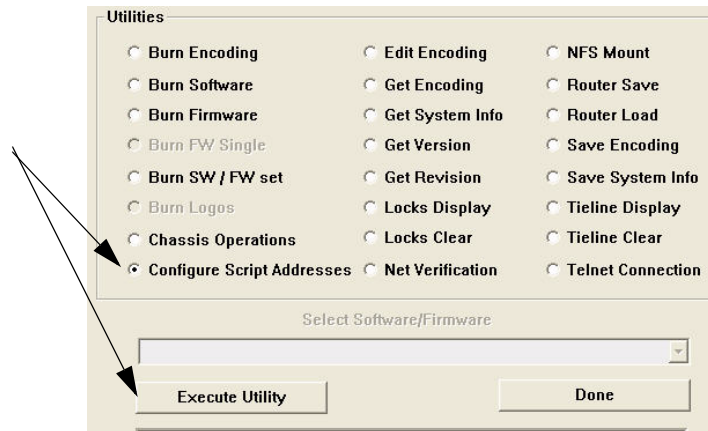



This will prompt you to enter the correct pc address first followed by the correct device address.

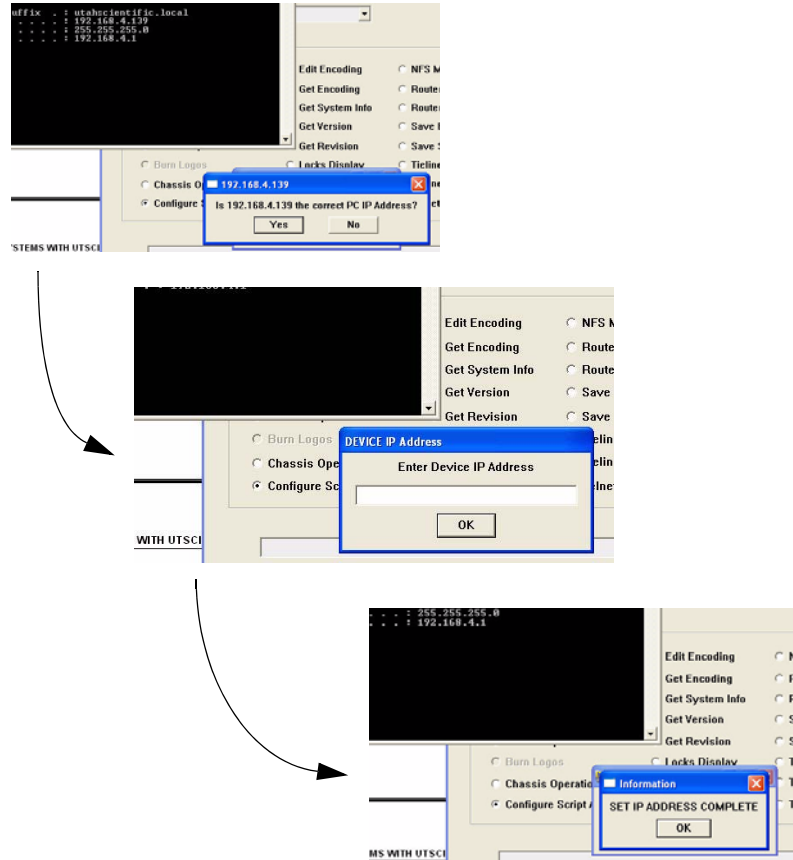

It will retain this for all remaining utility functions.

You are now ready to use the remaining Utilities. For further details on using these functions refer to the section above titled "Remaining Utilities and Help Functions".

## 'Install Application Software on PC'

Using the Utsci Install Utility, click on the button titled, 'Install Application Software on PC' as seen in the figure below.

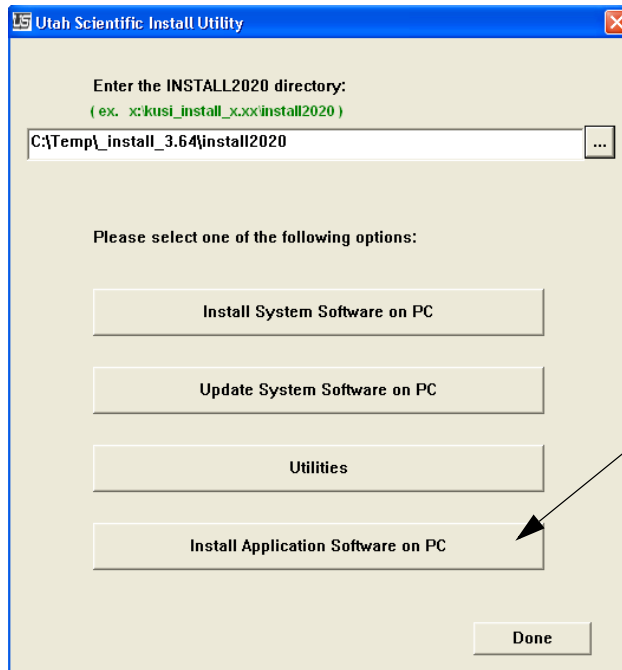

The following window will appear with a drop down selection for the software that is on the system CD that may be installed on the PC. Select the desired application to install and then click the button called 'Setup' in that same window.

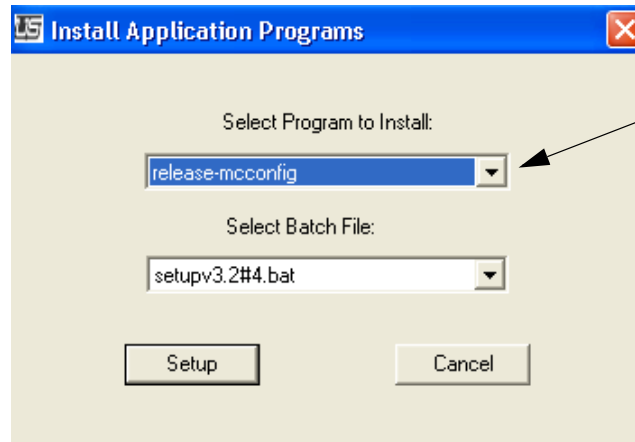

The following is a description and picture for each of the applications.

release-mcconfig - This is the application used to program the MC4000, MC400, MC40 and MC2020 master control channels. Refer to the MCconfig manual for details on how to use this application.

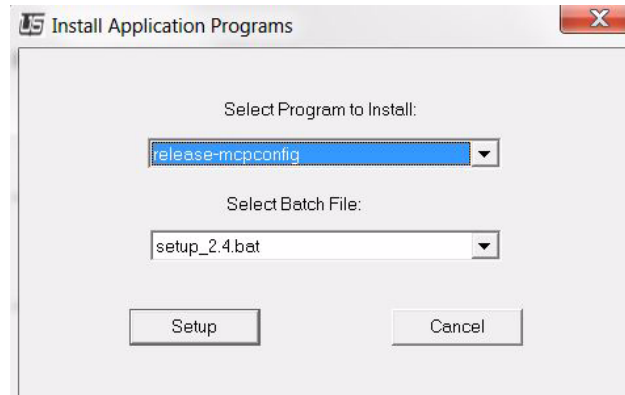

release-mcpconfig – This is the application used to program the various buttons on the MCP2020 control panel. Refer to the MCPconfig manual for details on how to use this application.

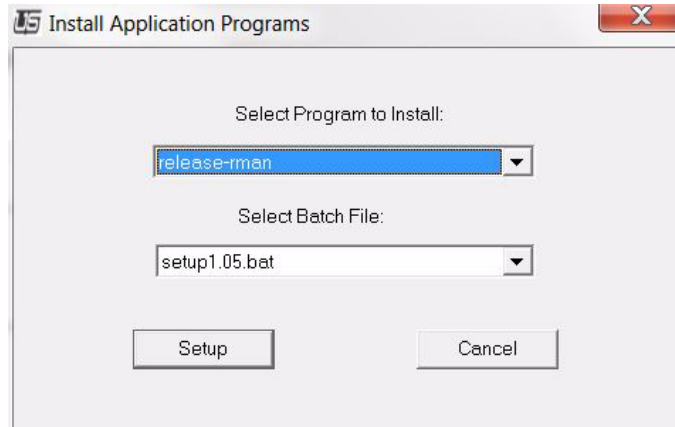

release-rman – This is the application used to view the system event log, the source and destination tables that are programmed into the SC4/SC400/SCX400 controllers and the real time switches that occur on the system. NOTE: This version is used with versions prior to software v2.0 in the controllers, such as v1.98 and older. Refer to the rMan Operations guide for details on how to use this application.

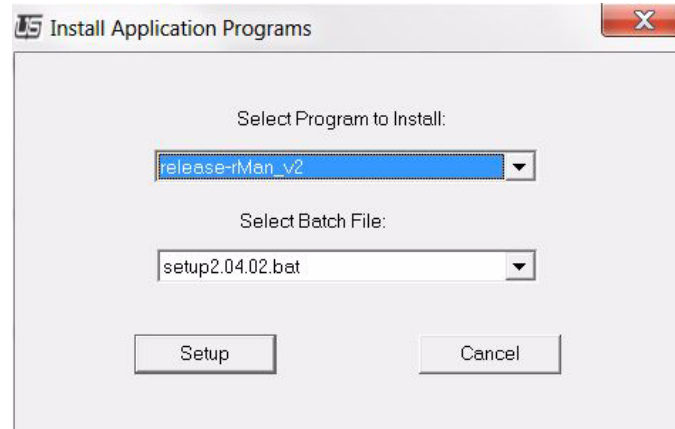

release-rman\_v2 – This application is a much more enhanced version of RMAN. It is still used to view the system event log, the source and destination tables that are programmed into the SC4/SC400/SCX400 controllers and the real time switches that occur on the system. However, it is also used to view the actual routers that are connected to the MXBus,





showing alarm status for most of the components. It also shows bus locks and allows those to be cleared or selected from the tables. Tie line management is available with this as well, showing and clearing tie lines from the tables. NOTE: This version is used with version v2.0 and newer in the controllers. Refer to the rMan V2 Operations guide for details on how to use this application.

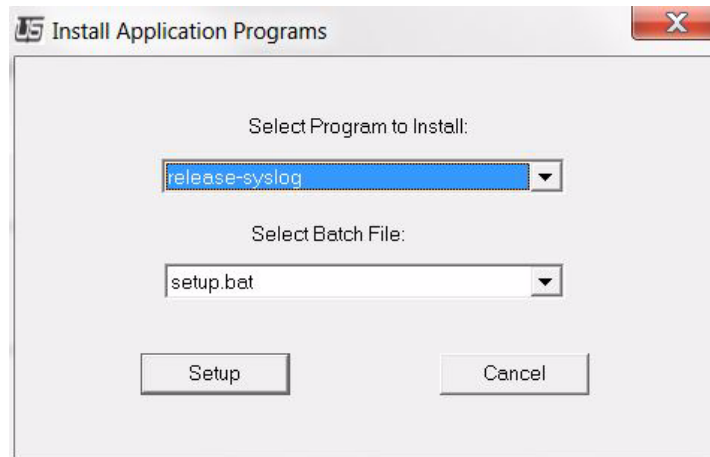

release-syslog – This is a logging application which will capture every event that occurs on the system, including serial takes via automation, UNET and Ethernet takes that occur over the network, Master Control events as well as multiple other items.

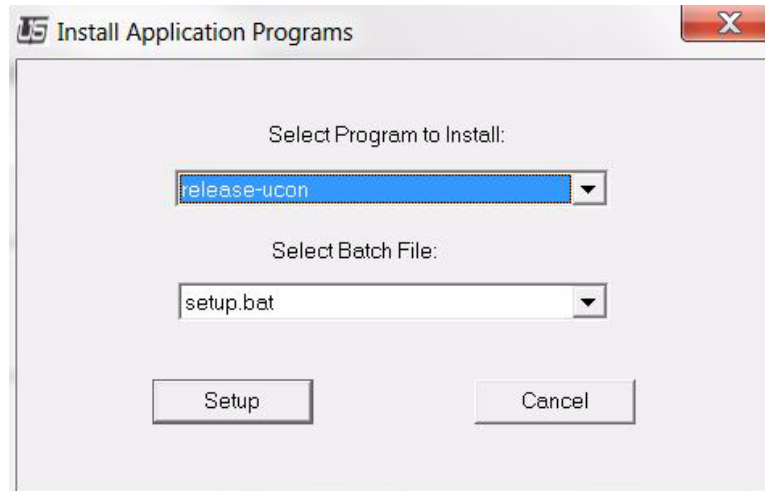

release-ucon – This is the application used to program the sources and destinations into the SC4/SC400/SCX400 control cards as well as programming the router control panels. It is also used for master control encoding and Soft Panel creation. Setting up serial ports and tie lines are also done from this software. NOTE: This version is used with versions prior to software v2.0 in the controllers, such as v1.98 and older. Refer to the U-CON Operations Guide for details on how to use this application.

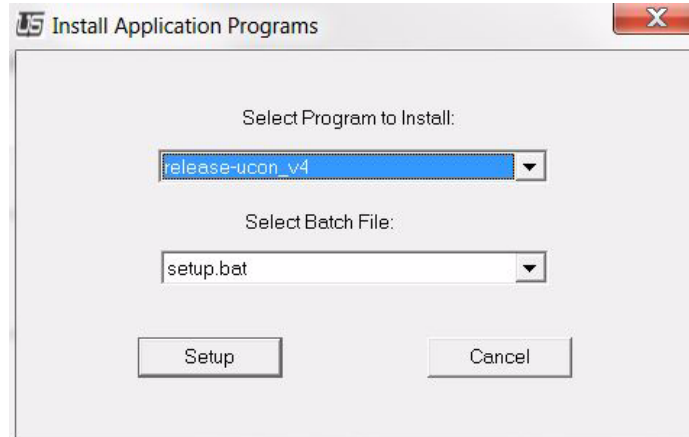

release-ucon\_v4 – This application is a much more enhanced version which is still used to program the sources and destinations into the SC4/SC400/SCX400 control cards as well as programming the router control panels. However, it is much more user interactive. It is also used for master control encoding and Soft Panel creation. Setting up serial ports and tie lines are also done from this software. NOTE: This version is used with version v2.0 and newer in the controllers. Refer to the U-CON V4 Operations Guide for details on how to use this application.

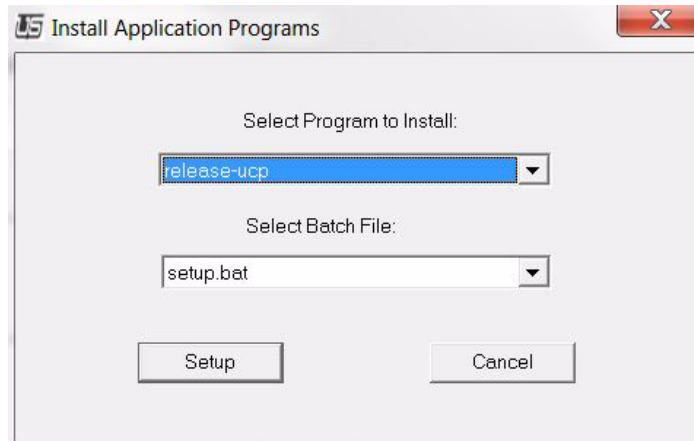

release-ucp – This will install a folder in the c:\usi folder called 'ucp' which is used to upgrade router control panels only.

## Remaining Utilities and Help Functions

To use the help function that describes each of the utilities simply click on the question mark in the upper right corner of the Utility screen for any device and then click on the actual utility.

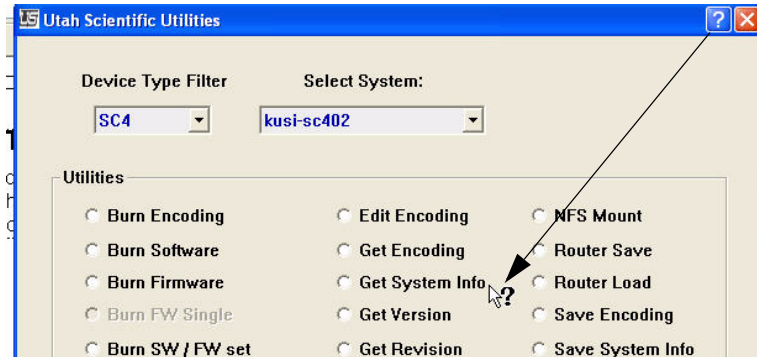

This will display a brief description of that utility. The following is a list of these Utilities and their functions.

Note: When burning software and firmware you will need to drop down the "Select Software/Firmware" list and choose the file to load.

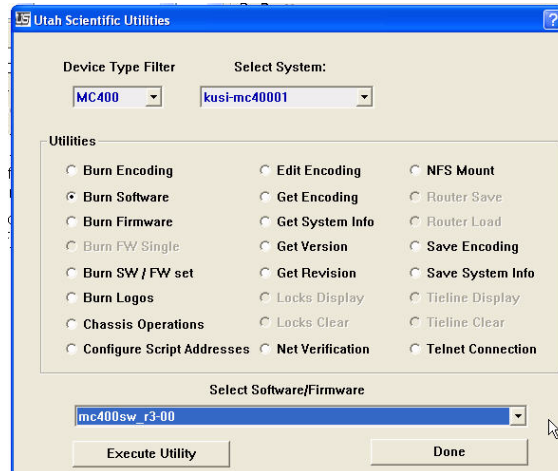

This Utility will only allow SW/FW versions from system CD v3-41 and newer to be loaded into any device. If you have a need to downgrade any device to something prior to this you will need to use the original script files from the c:\backup\usi folder created earlier.



## **Batch File Selection (Utility Help List)**

Note that there are certain functions (such as software burning) that cannot be completed until another function (version selection) takes place.

The single-line display provides shorter, immediate activity relation to the operation. This allows the last selected status to remain on-screen indefinitely, until another action is selected or the program is closed.

The larger pop-out dialog window contains more comprehensive detail related to the selected operation

### ***Net Verification***

This utility provides verification for network communications between the PC and the USI target device, such as a SC-4.

### ***Burn Software***

This utility updates the flash memory of a USI target device, such as a SC-4 Router Controller.

### ***Burn Firmware***

This utility updates the programmable logic devices (FPGA's) of a USI target device, such as a SC-4 Router.

### ***Burn SW / FW Set***

This utility updates a USI target device with new software and firmware that are known to work together.

### ***Burn Encoding***

This utility updates a USI target device with encoding stored in a file on the local PC hard drive.

### ***Get Encoding***

This utility downloads encoding information from a USI target device and stores it in a file on the local PC hard drive.

### ***Save Encoding***

This utility copies the encoding stored on the local hard drive to the windows desktop.

### ***Burn Logos***

This utility updates the flash memory of the USI master control devices, replacing existing files with new ones stored on the local PC hard drive.

### ***Get System Info***

This utility generates a detailed report for a USI target device and stores it to a file on the local PC hard drive, which is typically sent to USI Customer Service. *Use the Save System Info utility to copy the file to your desktop for easy access.*

### ***Get Version***

This queries a USI target device for its current software version and displays it in the message window.

### ***Get Revision***

This queries a USI target device for its current software revision, Firmware revision, and board inventory, then displays the information in the terminal window.

### ***NFS Mount***

This opens a telnet terminal and causes a USI target device to map the local PC hard drive as a remote drive, allowing access to files stored on the local PC hard drive.

### ***Telnet Connection***

This utility allows a convenient telnet connection to a USI target device.



### ***Router Save***

This updates a USI router controller with a file generated with the Router Save utility. This effectively returns the router control system status to a previous state.

### ***Edit Encoding***

This opens the encoding file for a USI target device stored on the local PC hard drive using Wordpad. You can then easily make file changes.

### ***Router Load***

This updates a USI router controller with a file generated with the Router Save utility. This effectively returns the router control system status to a previous state.

### ***Tieline Display***

This opens a telnet terminal and displays the current tieline status on the terminal screen.

### ***Tieline Clear***

This utility clears out all tieline controls, essentially resetting the Tieline processing engine in a USI router controller.

### ***Locks Display***

This opens a telnet terminal and displays the current lock status for a USI router system controller.

### ***Locks Clear***

This utility removes all active locks in a USI router control system.

### ***Configure Script Addresses***

This utility allows the user to enter or modify the IP addresses used by the utilities on the Local PC hard drive. This does not modify the IP address in a USI target device. That must be done using the Chassis Ops utility.

### ***Chassis Operations***

This utility allows the user to modify various settings in a USI target device, including the IP address, Chassis Name, Customer Name, and UNET node #

### ***Save System Info***

This utility copies the system information report generated with the Get System Info utility to the Windows desktop for easy access by the user.





### Updating Existing System Software Folders

This “Update System Software on PC” button is used to add new software and firmware release folders and their programming files into the already existing device folders located in the c:\usi directory. This process will leave all existing folders in their place and simply add the new update folder in with all of these existing ones.

Note: The Utsci Install Utility will NOT work with CD versions older than v3.41. If your system has been initially installed with a CD with numbers smaller than 3.41 (i.e. 3.39; 3.40,etc) then you need to follow the instructions found in the section above titled “Using the New Utsci Install Utility”. The Update System Software button is ONLY to be used with systems newer than v3.41 and to be used properly you would be running the Utility from the newer CD which would have a number larger than 3.41 (i.e. 3.42; 3.43,etc).

To Update existing system software folders you will need to follow these steps.

1. Copy the new system CD which will be v3.42 or newer to the c:\drive.
2. Launch the Utsci Install Utility application and in the top window browse to the Install2020 directory found in the release CD installed in step 1.

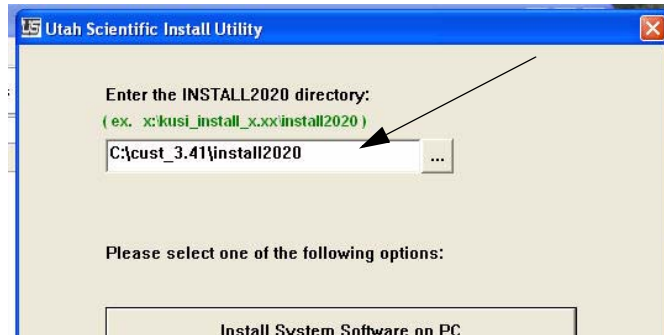

3. Click on “Update System Software on PC” button.

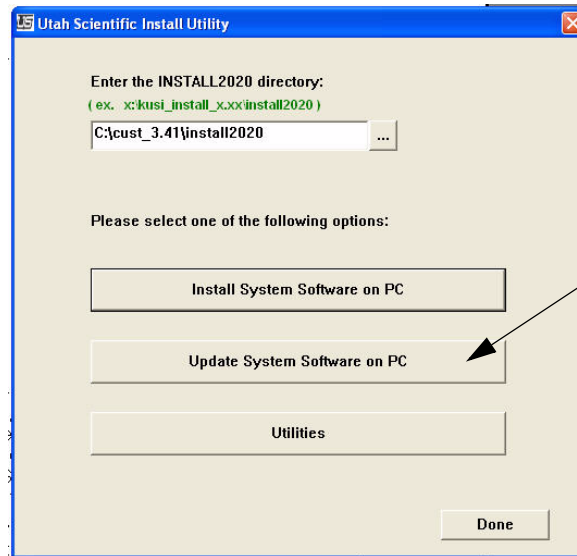

4. In the window that opens, drop down the “Device Type Filter” menu and select one of the devices in your system such as the SC4 or SC400.



Note: These represent physical devices you have in your system. The devices labeled CBSHD, ESI, HD, MCP and SD are all MC2020 products. All the other devices are self descriptive of what they represent.

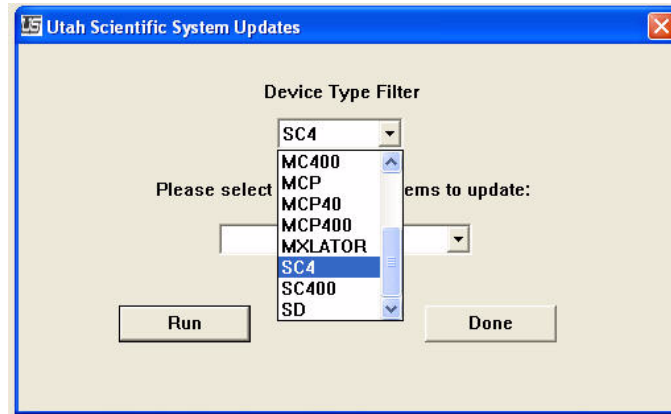

5. After selecting the filter type, drop down the system list to update. This will only show all folders in the c:\usi directory that end with the device type name that was selected in the filter.

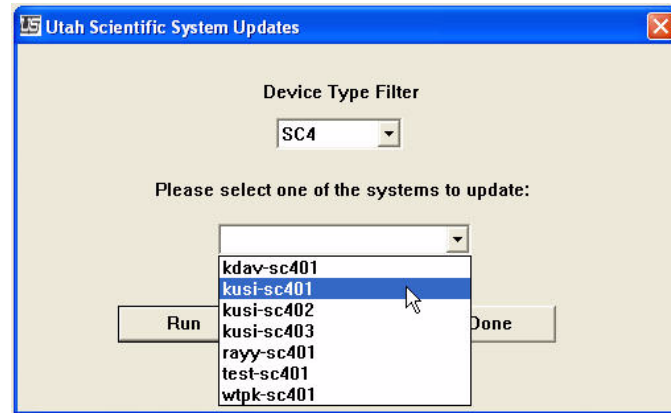

6. Click on the **Run** button and this will update the device folder with the new additions found on this CD.

## **What's Next?**

The next section covers Additional Setup, including Device Software Lookup, IP Address configuration, and using Tera Term Pro.



# 2

## Section 2

# Additional Setup

Complete the following to verify the success of the upgrade:

## Device Software Lookup

Complete the following steps to lookup, or verify the software version in the SC4, SC400, MXLator, MC2020, MCP2020 and ESI2020.

**Note:** If the device is already connected to the network (and Tera Term is running), you can bypass steps 1 - 9, select the TCP/IP connection, and proceed to step #10.

1. Connect the UTSCI Serial port to the RJ-45 adapter (Marked SC-4/2020 on your PC COM port).
2. Place a standard straight through CAT 5 cable from the PC adapter to the front RJ-45 port on the desired device.
3. Launch Tera Term Pro, open the Setup menu, select Serial Port and complete the following:
4. Select the desired port (COM 1, 2, etc.)
5. Set the Baud Rate to 19200.
6. Set the Data to 8-bit.
7. Set the Parity to None.
8. Set the Stop to 1-bit.
9. Set flow control to None.
10. Click OK.

## Locating IP Addresses

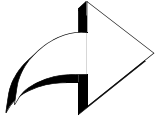

Use the following procedure to locate the IP address for your SC-4.

Make the connection from the PC's serial com port to the RJ-45 connector on the specific device, such as an SC-4. A labeled, RJ-45 9-pin adapter is included (SC-4/2020). A standard, straight-through CAT-5 cable is used.

Connect one end of the cable to the RJ-45 connector on the device and the other end to the adapter. Then connect the adapter to the 9-pin connector on the PC. *All devices contain an RJ-45 connector for this purpose.*

Make sure the current baud rate is 19,200, 8N1, and *no flow control*.

### ***Device IP Address Identification***

#### ***Launch Tera Term Pro***

From the **Start** menu, select *All Programs*, locate **Tera Term Pro**, then select the application.

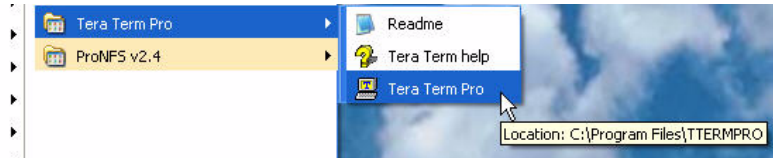

When the dialog appears, select the *Serial* button, then click **OK**.

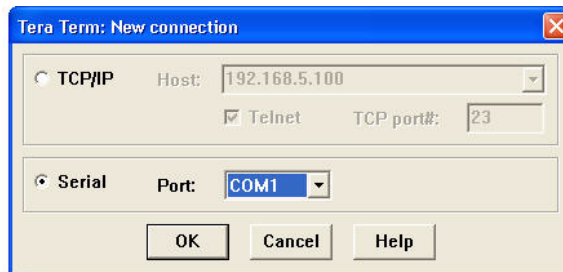



**Note:** The correct [physical] serial connection must be in place before the IP address identification is made (next step).

When the above dialog disappears, complete the following (next illustration): Press the RETURN key (first), then type **chassis -r** in the text-entry window, then press *Return* once again.<sup>1</sup>

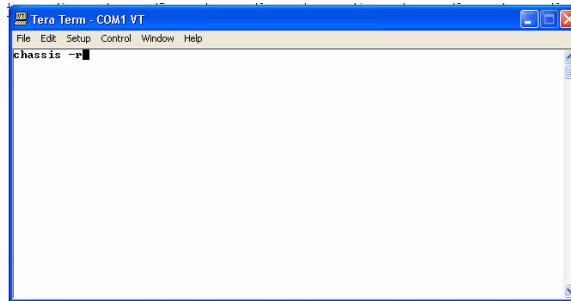

The 'NIC 1 IP Address' is the device address detail you will need.

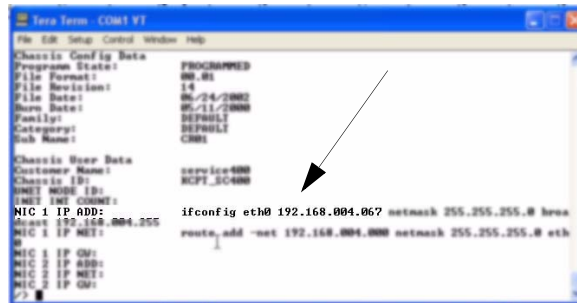

**Note:** If unsuccessful, you could also obtain the IP address by typing **ifconfig** at the prompt.

1. Again, make sure the current baud rate is 19,200, 8N1, and *no flow control*.

### PC Address Identification

As previously mentioned in Section 1 (page 1-20), locate your PC's IP address by activating your PC's DOS window -- holding the Windows™ key down and pressing the 'R' key. This activates the 'Run' dialog. Type **cmd** in the text field, then type **ipconfig**. A DOS window will appear containing your local IP address.

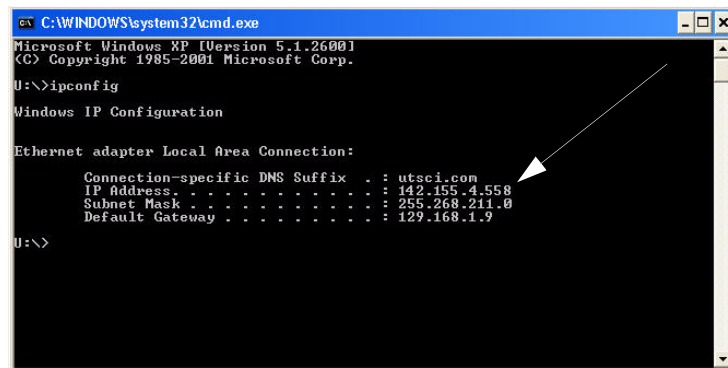
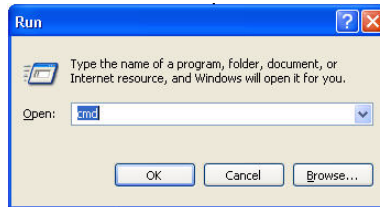

### What's Next?

*The next Section in the System Installation Process involves component interconnection (U-NET, MX-Bus, and Ethernet). Once the individual components are functioning properly, we will verify adequate communication among the devices in the larger array.*





# 3

## System Configuration

### Introduction

This section contains hardware setup and operational descriptions, applicable once the necessary software has been installed to your system. The following topics are covered:

- U-NET Interconnection
- MX-Bus Interconnection
- Ethernet Interconnection - information to follow

**Note:** *For the purpose of this discussion, “system controller” is used to refer to both SC-3 and SC-4 devices.*

## U-NET Interconnection

U-NET is an Utah Scientific-proprietary protocol used by the system controller to communicate with SCP/UCP control panels. Eight U-NET ports are located on the rear panel of the system controller.

### *Panel Support on the U-NET Ports*

Each U-NET port can support one or more SCP/UCP control panel(s), up to a maximum of 32 panels/port and 250 panels on all eight ports. Each port supports any combination of SCP or UCP panels. The maximum cable distance from each U-NET port to the last control panel (when U-NET Hubs are not used) is 1000 ft.

The last SCP/UCP panel on the end of each U-NET line must be terminated with a U-NET terminator. Any U-NET ports that are not connected to SCP/UCP control panels must be terminated directly at the port. Failure to adhere to these guidelines will result in faulty communications.

### *U-NET Cable Requirement*

The SCP/UCP panels are connected to the U-NET ports using a standard (straight-through) four-pair 10BaseT or 100BaseT Ethernet cable.

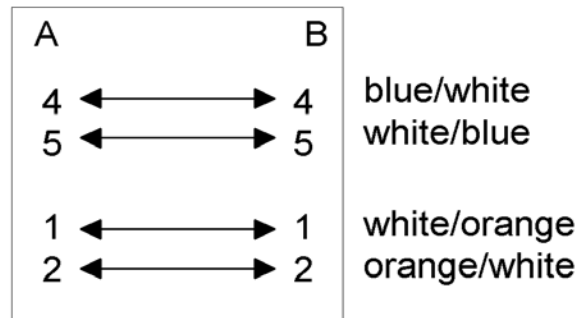

Figure 3-1. Pinouts for a U-NET Cable Connection



The same type of cable that is used for the straight-through Ethernet connection to your system controller can be used for U-NET connections, but the pairs that are utilized for communications are different. As you can see, the U-NET cable utilizes pairs 1 and 2.

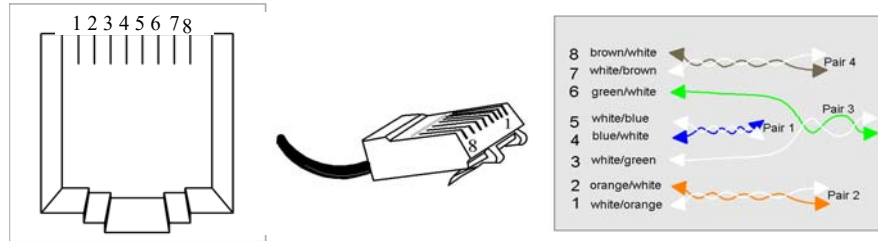

Figure 3-2. A straight-through Ethernet wiring diagram for U-NET

### U-NET Cable Topologies

SCP/UCP panels can be connected to the system controller's U-NET ports in a number of different topologies, depending upon the overall size and application of the installation. Most applications fit into one of two basic configurations—the *daisy chain* and the *star*. Combinations of star and daisy chain configurations can also be used.

#### A basic daisy chain configuration

A daisy chain is a configuration where multiple SCP/UCP panels are connected to a U-NET port on the system controller via a chain of cables and panels. In its simplest form, each panel except the last one in the chain has two RJ-45 cable connections—one to the device prior to it in the chain, and one to the device after it in the chain. The loop-through port on the last panel must be terminated. The illustration shows a simple daisy chain from one of

the eight U-NET ports on the system controller to a string of 32 SCP or UCP panels. Notice that the unused U-NET ports on the system controller and the U-NET loop-through port on the last panel (SCP32) are terminated.

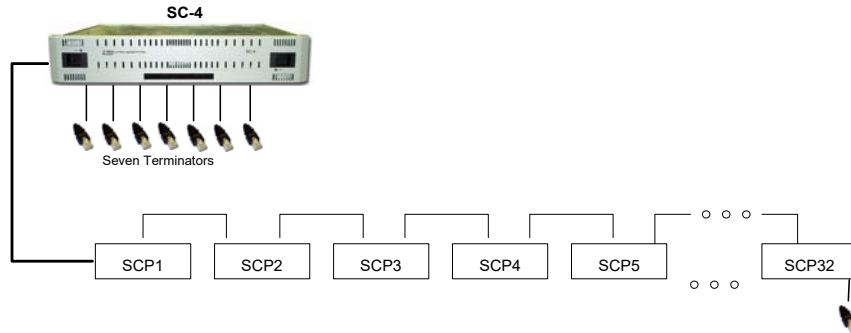

Figure 3-3. Daisy Chain Configuration

A daisy chain configuration such as the one shown above provides for a simple installation, but it does not lend itself well to troubleshooting—the removal of a panel in the middle of the chain will break communications with any panels past that point, and causes loss of termination for panels before that point.

### ***A daisy chain with RJ-45 T connectors***

To make troubleshooting a daisy chain configuration easier, you can use RJ-45 T connectors to connect each panel to the network. In this case, only one U-NET port on each SCP or UCP panel is required—the loop-through ports are not used. The illustration shows this type of configuration.

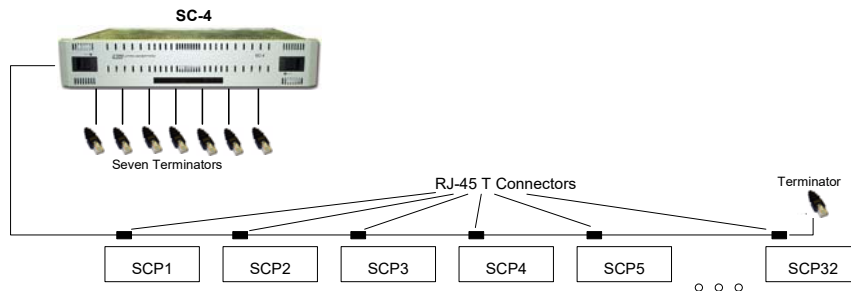

Figure 3-4. Daisy Chain configuration with RJ-45 connectors



This use of T connectors allows you to remove individual panels from the chain without breaking the chain to other panels. The loop-through ports on the SCP or UCP control panels do not need to be terminated when the RJ-45 T connectors are used. Termination needs to be provided on the unused U-NET ports on the system controller and at the last SCP/UCP panel in the chain. The last SCP/UCP panel may be terminated either at the T connector or at its loop-through U-NET port.

### Star configurations

A star configuration is created by connecting each SCP/UCP panel (up to eight) to its own U-NET port on the system controller. The illustration contains a star configuration where all eight U-NET connectors on the system controller are utilized.

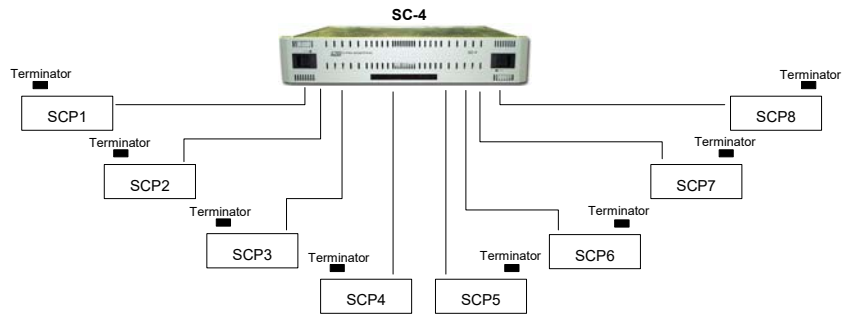

Figure 3-5. A Star Configuration

**Note:** *The loop-through port on each UCP/SCP panel requires termination.*

Star configurations are easy to troubleshoot and maintain because each control panel can be removed from the system without affecting any other panels on the system controller.

### Combining daisy chain and star topologies in a configuration

In order to maximize the number of SCP/UCP panels controlled by a system controller, you can use a star configuration to connect to multiple U-NET ports on the controller, then daisy chain multiple panels off various legs of the cable system. The system controller allows you to build systems in this manner that support as many as 250 SCP/UCP panels.

The next figure shows an example of a four-legged star configuration with four daisy chains, each chain containing 32 SCP/UCP panels.

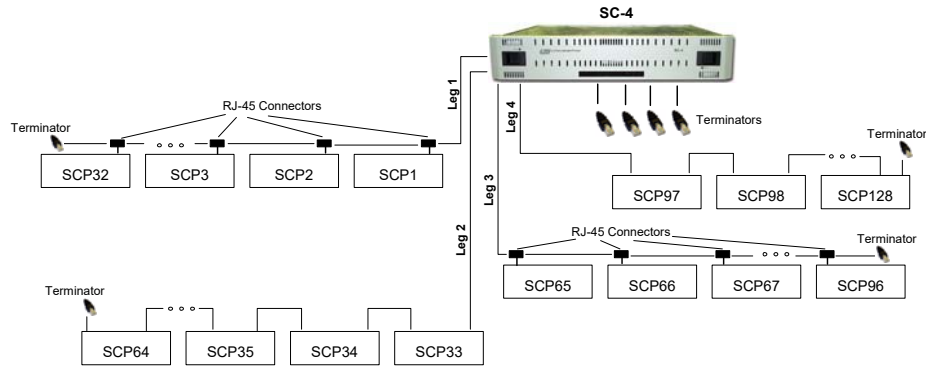

Figure 3-6. A combined Star/Daisy Chain configuration

In this example, the daisy chains off the first and third legs use RJ-45 T connectors; the daisy chains off the second and fourth legs use simple loop-through connections between SCP/UCP panels.

Notice that the termination rules for simple and T-conductor daisy chains apply here.

### Extending a U-NET Configuration with U-NET Hubs

For applications that require distances greater than 305 m (1000 ft) between an system controller and the SCP/UCP panels supported by that controller, a U-NET Hub can be used. A U-NET Hub contains one U-NET input port and eight U-NET output ports, and it can extend the cable distance by an additional 305 m (1000 ft) from each output port. Standard 10BaseT or 100BaseT cables should be used for all connections.

**Note:** *U-NET Hubs are designed specifically for use with Utah Scientific's U-NET protocol—they cannot be replaced with standard Ethernet Hubs.*

U-NET Hub can be ordered from Utah Scientific with a DC power supply (part number 80263-5) or an AC power supply (part number 80263-2).



### Using one U-NET Hub on an System Controller's U-NET port

The next figure shows how a U-NET Hub can increase the distance between the system controller and the last SCP/UCP panel on a U-NET connection to 2000 ft.

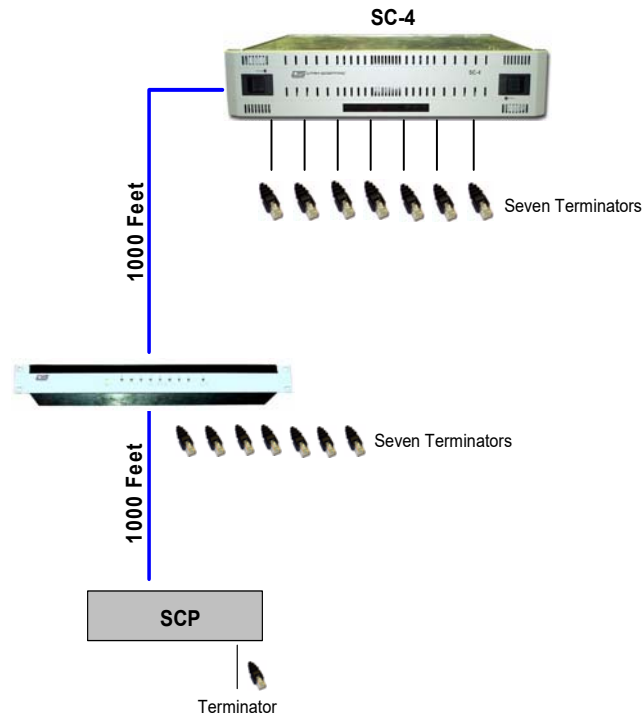

Figure 3-7. Doubling the distance with one U-NET hub

Unused U-NET input ports on the U-NET Hub are internally terminated. **However, though external termination is not absolutely required, it is always best to terminate the unused ports.**

The last SCP/UCP panel in the U-NET cable run must be terminated.

Each U-NET Hub output port can support a daisy chain of as many as 32 panels, up to a combined total not to exceed 250 panels on the system controller. U-NET Hub output ports support any combination of SCP/UCP panel models.

## MX-Bus Interconnection

MX-Bus is a bidirectional parallel communications link over which the system controller sends commands to and receives status from UTAH-400 crosspoint matrices. Data is repeatedly transmitted to refresh the matrix states and check for errors. MX-Bus supports a 1152 input x 1152 output x 16 level matrix.

### ***System Controller (SC-4) connections***

Two 25-pin male D-shell MX port connectors are located on the bottom mid-section of the SC-4's rear panel. The figure below shows a closer view of the two connectors.



Figure 3-8. The MX-Bus Connectors (SC-4 rear)

Connect one port to one of the ports in the UTAH-400 routing switcher matrix with a 80229-10 control cable, which ships with the SC-4 controller. Terminate the other port with a 70797-1 MX-Bus terminator, which also ships with the SC-4. The second port on the UTAH-400 routing switcher matrix should either be terminated or looped through to the next chassis; the last chassis in the MX-Bus chain must be terminated with a 70797-1 MX-Bus terminator.

### ***Cable requirements***

It is desirable to keep the cable runs as short as possible and to avoid unnecessary cable loops in the cabinets. You should connect the 80229-10 control cable running from the MX port connector to the matrix chassis that is physically closest to the system controller. Use additional lengths of 80229-10 control cable to interconnect each of the routing switcher frames in the UTAH-400 system. The total of the connected cables in the daisy chain should be no more than 91.4 m (300 ft) in length.





There may be cases where you will need to fabricate a cable if the distance between elements in the link is long. A suitable cable type is Belden 9684 or equivalent (E57891). The following table contains the MX port pinouts and the associated wire colors.

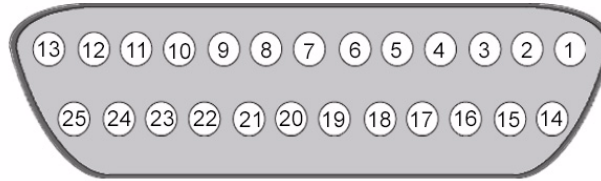

1	Strobe	white/blue	14	N/A	red/gray
2	D0	white/orange	15	GND	blue/white
3	D1	white/green	16	N/A	gray/red
4	D2	white/brown	17	N/A	black/blue
5	D3	white/gray	18	GND	orange/white
6	D4	red/blue	19	GND	green/white
7	D5	red/orange	20	GND	brown/white
8	D6	red/green	21	GND	gray/white
9	D7	red/brown	22	GND	blue/red
10	N/A	blue/black	23	GND	orange/red
11	N/A	black/orange	24	GND	green/red
12	N/A	orange/black	25	GND	brown/red
13	+5 V	N/C (open)			

Figure 3-9. Pinouts for the MX Port

The current 80229-10 control cable is built using low-capacitance 28 gauge parallel digital video cable. The data lines (D0 ... D7) are true high. The strobe line is true low. Pin 13 provides power to the strobe pull-up and should not be connected through the cable.

**Notes:** *An optional MX-Bus Hub is also available if you prefer to connect the bus in a star configuration as opposed to a daisy chain. Also, the cable contains twisted pairs, and the data lines are each twisted with a [ground].*

## Ethernet Interconnection

### *Options and Requirements*

The U-CON V4 software runs on a Windows 2000 or XP platform and provides the Graphical User Interface (GUI) through which you configure the router matrix and the control panels before the system is operational. The rMan V2 can be used in a router switching system, after it has been made operational, to display numerous router and control panel statuses and diagnostic statistics.

The U-CON V4 communicates with a system controller over a 100 Base T Ethernet cable. The link between the system controller and the U-CON V4 computer can be configured in several different ways.

### *Ethernet Cabling Configurations*

There are two basic types of cable configurations for linking the system controller and the computer running the U-CON V4 — **stand-alone** and **networked** Ethernet links.

#### **Standalone configurations**

In the stand-alone configuration, the Windows PC running the U-CON V4 software is linked directly to the system controller with a single cable — the PC is not tied to a network. A nonstandard Ethernet cable, commonly called a **crossover** cable, can be used, as shown in Figure 3-10.

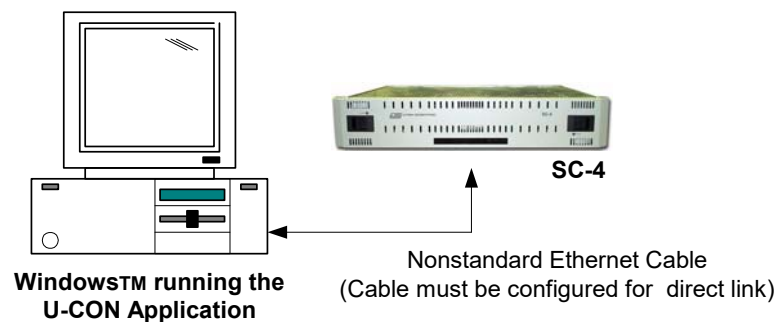

Figure 3-10. Stand-alone Crossover Ethernet Configuration

The pinout for the crossover cable is depicted in the following illustration.



Figure 3-11. Pinouts for a Crossover Ethernet Cable

Alternatively, you can use standard *straight-through* Ethernet cables in your stand-alone configuration by introducing a 100 Base T Hub in the configuration between the PC and the system controller.

Figure 3-12 shows a standard straight-through Ethernet configuration.

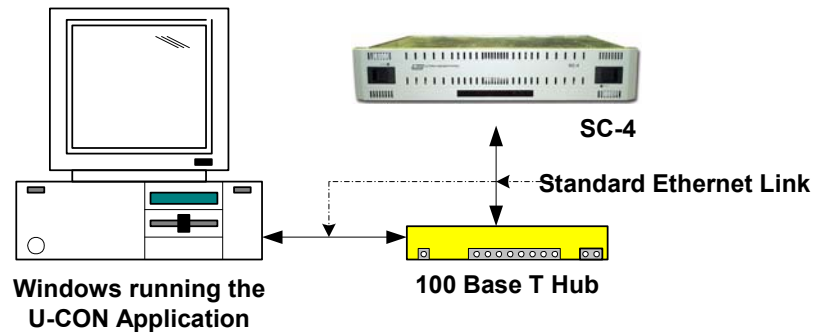

Figure 3-12. A stand-alone straight-through Ethernet Configuration

A cable pinout for the standard straight-through Ethernet cable is shown in Figure 3-13.



Figure 3-13. Pinouts for a straight-through Ethernet cable

Figure 3-14 shows the wiring diagram for a straight-through Ethernet cable.

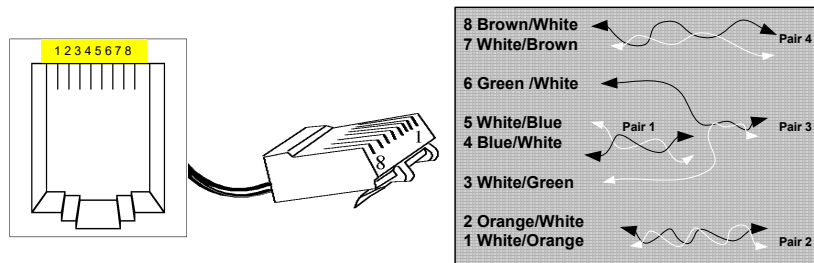

Figure 3-14. A straight-through Ethernet wiring diagram

The pairs that carry the Ethernet signal are pair 3 and pair 2 (in both the crossover and straight-through connections). The remaining wires are not used in the actual communications for 10 Base T, but they may be connected in a straight-through manner (for both crossover and straight-through connections).



**Note:** Wires in each of the pairs 3 and 2 must remain in that pair to retain the balance properties of the cable. In other words, pair 2, which resides on pins 1 and 2 of the RJ-45 jack, should occupy the white/orange and orange/white wires of the cable. Pair 3, which resides on pins 3 and 6 of the RJ-45 jack, should occupy the white/green and green/white wires.

### Caution

Category 5 UTP cable should always be used. Failure to adhere to these guidelines will result in faulty communications.

### Network Configurations

In a networked configuration, the Windows PC running the U-CON V4 software is on a local or wide area network (LAN or WAN). The PC must plug into a 100 Base T Hub to access the network. The system controller also plugs into a Hub on the network, as shown in the following illustration.

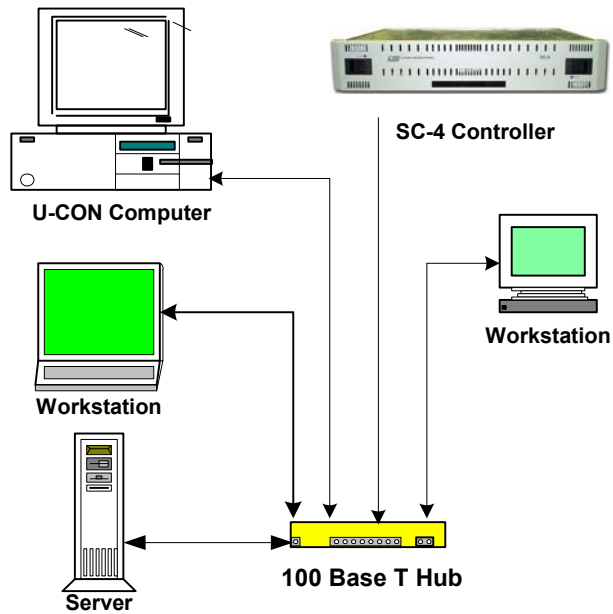

Figure 3-15. A network configuration

The cable used to link the system controller to the network Hub is a standard off-the-shelf 100 Base T Ethernet cable with the same pinouts as shown in Figures 3-13 and 3-14.

**Note:** *Although more than one computer can run the U-CON V4 application on an Ethernet, only one U-CON V4 computer should attempt to access the system controller (SC-4) at a time.*

### **Caution**

**Category 5 UTP cable should always be used. Failure to adhere to these guidelines will result in faulty communications.**



# 4

## Additional Update and Installation

### Remaining Utilities and Help Functions

To use the help function that describes each of the utilities simply click on the question mark in the upper right corner of the Utility screen for any device and then click on the actual utility.

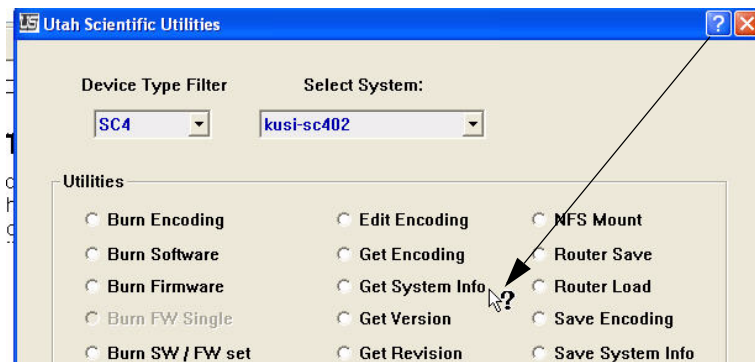

This will display a brief description of that utility. The following is a list of these Utilities and their functions.

Note: When burning software and firmware you will need to drop down the “Select Software/Firmware” list and choose the file to load.

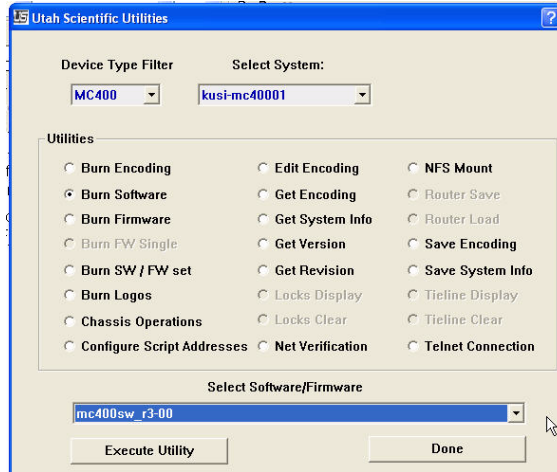

This Utility will only allow SW/FW versions from system CD v3-41 and newer to be loaded into any device. If you have a need to downgrade any device to something prior to this you will need to use the original script files from the c:\backup\usi folder created earlier.





## **Batch File Selection (Utility Help List)**

Note that there are certain functions (such as software burning) that cannot be completed until another function (version selection) takes place.

The single-line display provides shorter, immediate activity relation to the operation. This allows the last selected status to remain on-screen indefinitely, until another action is selected or the program is closed.

The larger pop-out dialog window contains more comprehensive detail related to the selected operation

### ***Net Verification***

This utility provides verification for network communications between the PC and the USI target device, such as a SC-4.

### ***Burn Software***

This utility updates the flash memory of a USI target device, such as a SC-4 Router Controller.

### ***Burn Firmware***

This utility updates the programmable logic devices (FPGA's) of a USI target device, such as a SC-4 Router.

### ***Burn SW / FW Set***

This utility updates a USI target device with new software and firmware that are known to work together.

### ***Burn Encoding***

This utility updates a USI target device with encoding stored in a file on the local PC hard drive.

### ***Get Encoding***

This utility downloads encoding information from a USI target device and stores it in a file on the local PC hard drive.

### ***Save Encoding***

This utility copies the encoding stored on the local hard drive to the windows desktop.

### ***Burn Logos***

This utility updates the flash memory of the USI master control devices, replacing existing files with new ones stored on the local PC hard drive.

### ***Get System Info***

This utility generates a detailed report for a USI target device and stores it to a file on the local PC hard drive, which is typically sent to USI Customer Service. *Use the Save System Info utility to copy the file to your desktop for easy access.*

### ***Get Version***

This queries a USI target device for its current software version and displays it in the message window.

### ***Get Revision***

This queries a USI target device for its current software revision, Firmware revision, and board inventory, then displays the information in the terminal window.

### ***NFS Mount***

This opens a telnet terminal and causes a USI target device to map the local PC hard drive as a remote drive, allowing access to files stored on the local PC hard drive.

### ***Telnet Connection***

This utility allows a convenient telnet connection to a USI target device.



### ***Router Save***

This updates a USI router controller with a file generated with the Router Save utility. This effectively returns the router control system status to a previous state.

### ***Edit Encoding***

This opens the encoding file for a USI target device stored on the local PC hard drive using Wordpad. You can then easily make file changes.

### ***Router Load***

This updates a USI router controller with a file generated with the Router Save utility. This effectively returns the router control system status to a previous state.

### ***Tieline Display***

This opens a telnet terminal and displays the current tieline status on the terminal screen.

### ***Tieline Clear***

This utility clears out all tieline controls, essentially resetting the Tieline processing engine in a USI router controller.

### ***Locks Display***

This opens a telnet terminal and displays the current lock status for a USI router system controller.

### ***Locks Clear***

This utility removes all active locks in a USI router control system.

### ***Configure Script Addresses***

This utility allows the user to enter or modify the IP addresses used by the utilities on the Local PC hard drive. This does not modify the IP address in a USI target device. That must be done using the Chassis Ops utility.

### ***Chassis Operations***

This utility allows the user to modify various settings in a USI target device, including the IP address, Chassis Name, Customer Name, and UNET node #

### ***Save System Info***

This utility copies the system information report generated with the Get System Info utility to the Windows desktop for easy access by the user.



### Updating Existing System Software Folders

This “Update System Software on PC” button is used to add new software and firmware release folders and their programming files into the already existing device folders located in the c:\usi directory. This process will leave all existing folders in their place and simply add the new update folder in with all of these existing ones.

Note: The Utsci Install Utility will NOT work with CD versions older than v3.41. If your system has been initially installed with a CD with numbers smaller than 3.41 (i.e. 3.39; 3.40,etc) then you need to follow the instructions found in the section above titled “Using the New Utsci Install Utility”. The Update System Software button is ONLY to be used with systems newer than v3.41 and to be used properly you would be running the Utility from the newer CD which would have a number larger than 3.41 (i.e. 3.42; 3.43,etc).

To Update existing system software folders you will need to follow these steps.

1. Copy the new system CD which will be v3.42 or newer to the c:\drive.
2. Launch the Utsci Install Utility application and in the top window browse to the Install2020 directory found in the release CD installed in step 1.

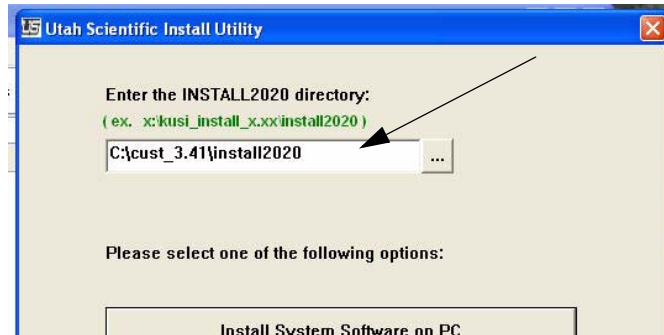

3. Click on “Update System Software on PC” button.

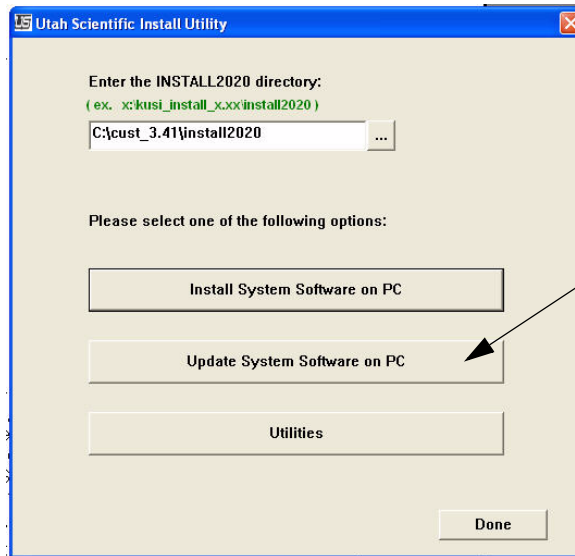

4. In the window that opens, drop down the “Device Type Filter” menu and select one of the devices in your system such as the SC4 or SC400.



Note: These represent physical devices you have in your system. The devices labeled CBSHD, ESI, HD, MCP and SD are all MC2020 products. All the other devices are self descriptive of what they represent.

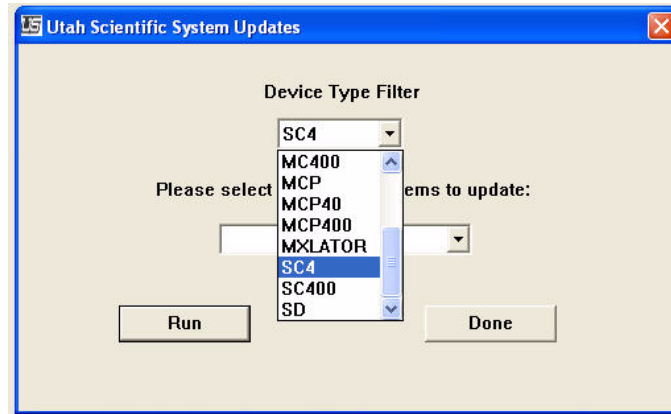

5. After selecting the filter type, drop down the system list to update. This will only show all folders in the c:\usi directory that end with the device type name that was selected in the filter.

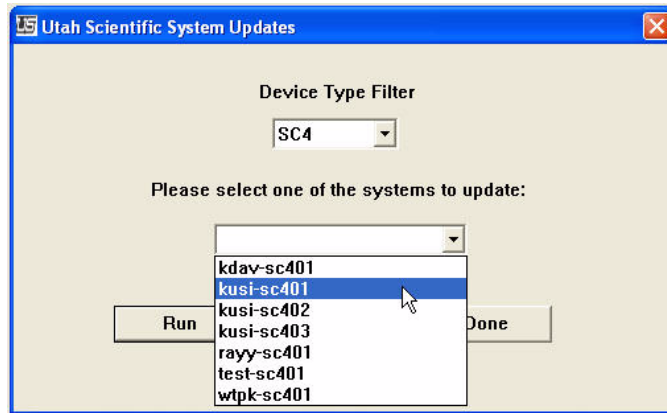

6. Click on the **Run** button and this will update the device folder with the new additions found on this CD.

### ***New Systems with the UTSCI Install Utility Already Installed***

Launch the application called "Utsci Install Utility". (Note: this application points to folders that were created in the c:\usi directory for each device on your system such as an SC4 controller and master control channel. It uses script files to look up critical information such as versions as well as retrieving and editing the current configuration files that are programmed into the device. It is also the tool for updating software and firmware into the device.)

Here are some bullets on utilizing this application.

(In the future) If you purchase a new device sometime after the initial install or wish to change the name of a folder in the c:\usi directory then refer to steps 7-9 in the section above titled "Using the New Utsci Install Utility". Note: if you wish to change the name after following these steps simply delete the original folder. You CANNOT just manually change the names of any folders found in c:\usi as the script files will no longer function.

(In the future) If you receive a new system CD with the version newer than v3.41 then you will need to update your current folders following the steps found in the section of this guide called "Updating Existing System Software Folders."





To use any of the Utilities click on the “Utilities” button.

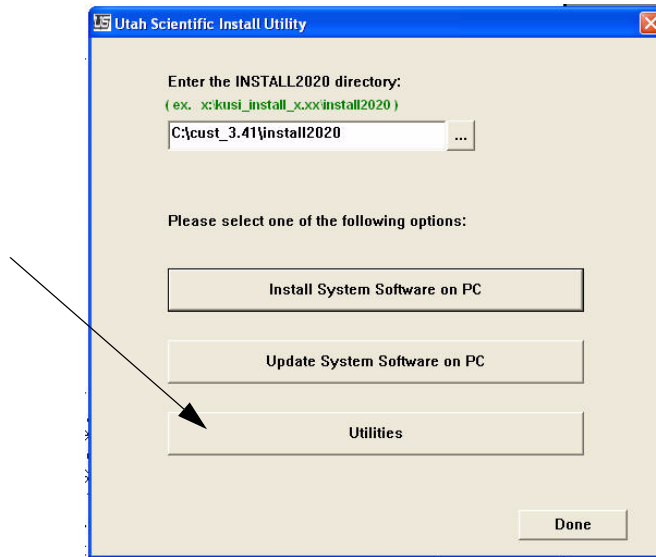

Note: If you do not already have the NFS Server running it will not allow you to proceed and you will get an error box indicating this.

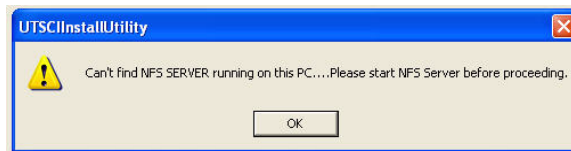

If the error does appear then go to your Utah Shortcuts folder and click on the NFS Server shortcut.



Then proceed to the next step.

Drop down the selection list for the Device Type Filter and select each device type one by one such as the SC4.

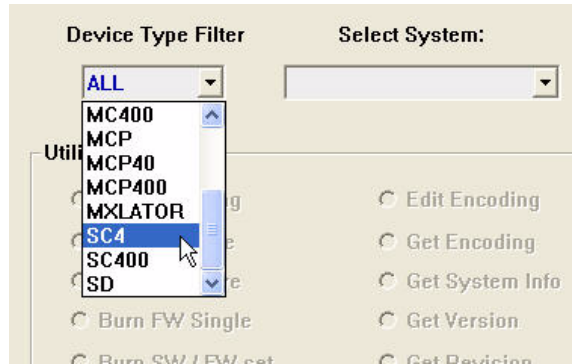

The devices labeled CBSHD, ESI, HD, MCP and SD are all MC2020 products. All the other devices are self descriptive of what they represent.

Drop down the selection list for the system you will be performing any utility on.

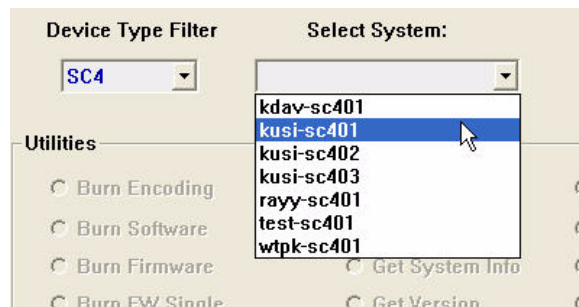

(Note: this will only display the system folders found in the c:\usi for that device type. I.e. – if a folder was created called KUSI and a device type for an SC4, then the list will only display a folder called kusi-sc401.)



At this point all of the possible utilities for the selected device will be activated.

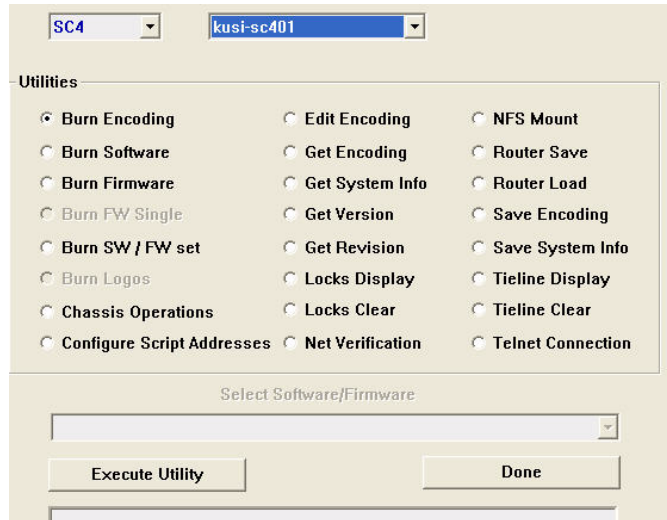

(Note: Unless Utah Scientific was supplied with IP addresses for each device then they would have been sent with default addresses and each utility will operate using those addresses and you can proceed along by skipping the next step.

IMPORTANT: If you wish to change each device address then you will need to run the Utility called “Chassis Operations” for each device and change the IP address as you are prompted to do so. Ignore any requests to change ID and customer name at this point by clicking no when asked.)

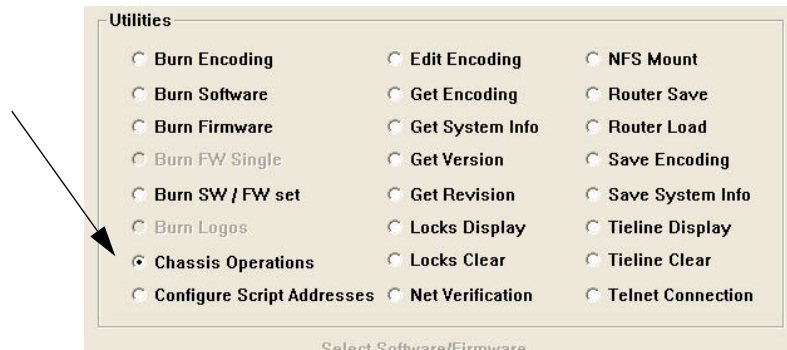

If you did make changes to the IP addresses in the previous step then you will need to enter the IP addresses for this device and the config pc into the script file location in this Install Utility application. Unless you change the IP address in the device. After this the Utility will remember the new IP address and this will be the only time you will need to set the addresses for the script files to function properly. Choose the “Configure Script Addresses” and then click on the “Execute Utility” button.

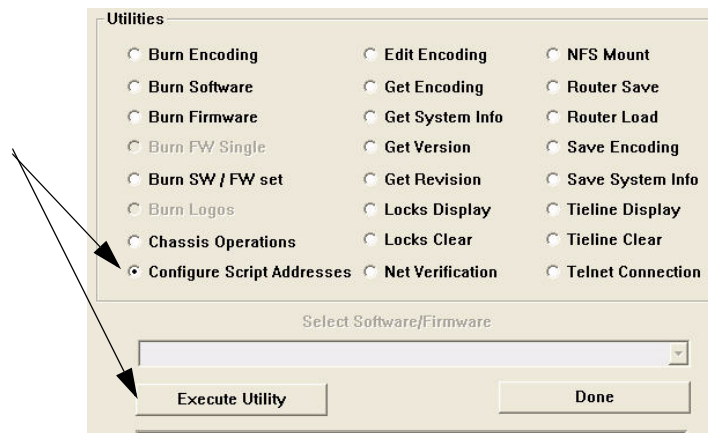



This will prompt you to enter the correct pc address first followed by the correct device address.

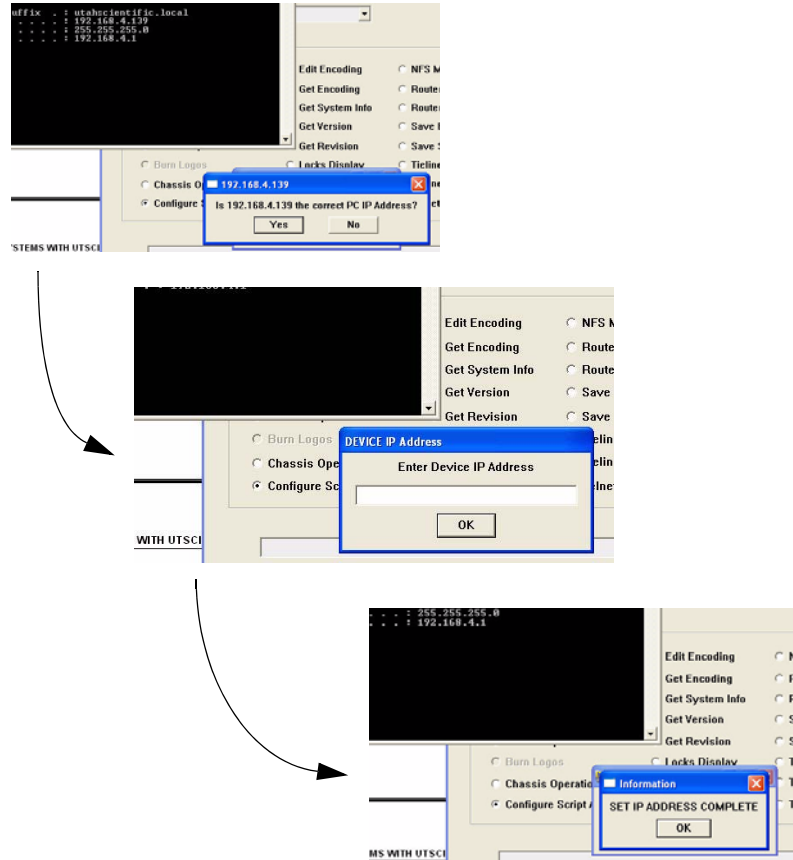

It will retain this for all remaining utility functions.

You are now ready to use the remaining Utilities. For further details on using these functions refer to the section above titled “Remaining Utilities and Help Functions”.

### ***Upgrading Device Software and Firmware Using the Utility***

ALL software will need to be upgraded to use this Utility, Ucon and the MCCConfig application. However, the firmware versions may not need to be upgraded as it may already be current. The following is a list of current firmware versions for all devices as of 3/14/2009. This section will describe how to check the version in the device and how to use the Utility to upgrade if needed. NOTE: All systems purchased after 5/1/2008 will most likely be current on the firmware versions.

#### ***Device Type FW Version***

SC4	2.18 or 2.21 (both are valid)
SC400	1.03 or 1.05 (both are valid)
SCX400	1.00
SD-2020 0301	All cards A5EE (ENG REV) 0300 (MNF REV) except VO is
HD-2020 0301	All cards A5EE (ENG REV) 0300 (MNF REV) except VO is
MCP-2020 command	3.09- Date will read 20080310 from Utility Get Revision
ESI-2020	3.06
MC-40 command	1.5- Date will read 20080428 from Utility Get Revision
MC-400 command	1.5- Date will read 20080428 from Utility Get Revision
MCP-40 command	2.01- Date will read 05282008 from Utility Get Revision
MCP-400 command	2.01- Date will read 05282008 from Utility Get Revision
MXLATOR	2.06

CHECK REVISIONS



Using table above, compare findings from these steps to verify firmware revisions. Look for the dates noted above in the screens that appear.

### Checking Firmware Revisions Using the New Utility

1. Launch the Utsci Installation Utility and on the main screen click the Utilities button.

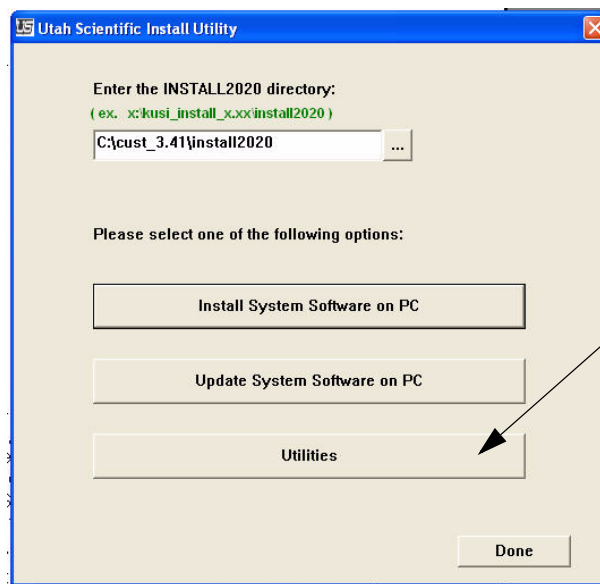

Note: if you do not already have the NFS Server running it will not allow you to proceed and you will get an error box indicating this.

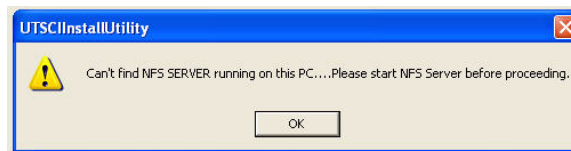

2. Drop down the selection list for the Device Type Filter and select each device type one by one such as the SC4.

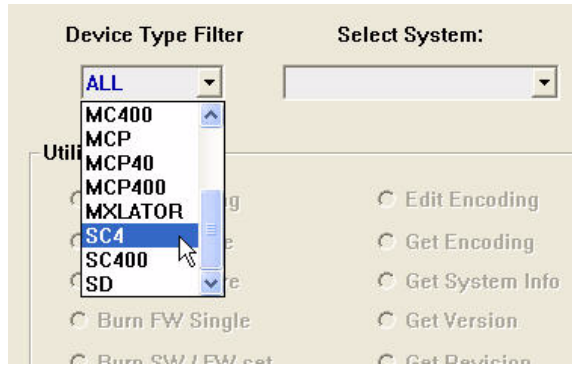

Keep in mind that the devices labeled CBSHD, ESI, HD, MCP and SD are all MC2020 products. All the other devices are self descriptive of what they represent.

3. Drop down the selection list for the system you will be retrieving the encoding from.

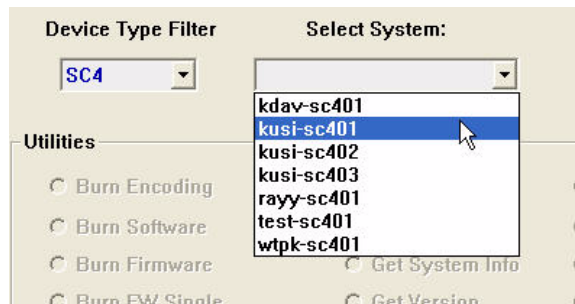

(Note: this will only display the system folders created above for that device type. I.e. – if you created a folder called KUSI and a device type for an SC4 then the list will only display a folder called kusi-sc401.)





4. All of the possible utilities for the selected device will be activated. You will need to enter the IP addresses for this device and the config pc you are using this application from.

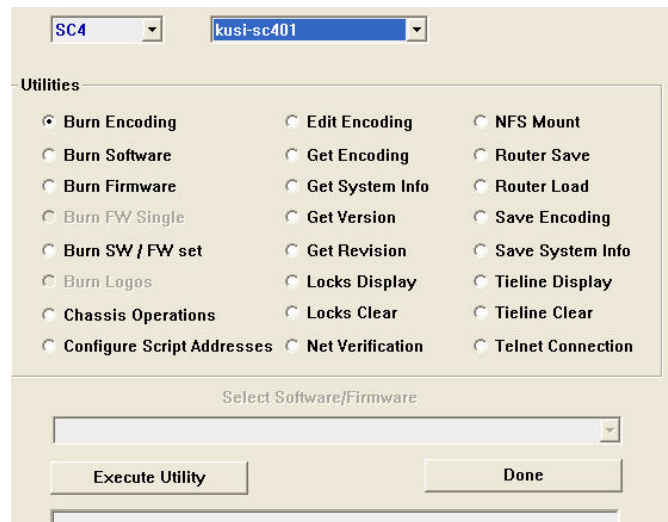

Unless you change the IP address in the device, this will be the only time you will need to set the addresses for the script files to function properly. Choose the “Configure Script Addresses” and then click on the “Execute Utility” button.

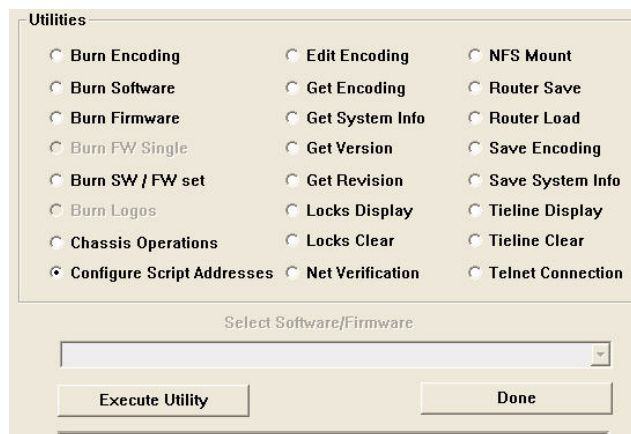

This will prompt you to enter the correct pc address first followed by the correct device address. It will retain this for all remaining utility functions.

5. Next choose the “Get Revision” button and then click on the “Execute Utility” button.

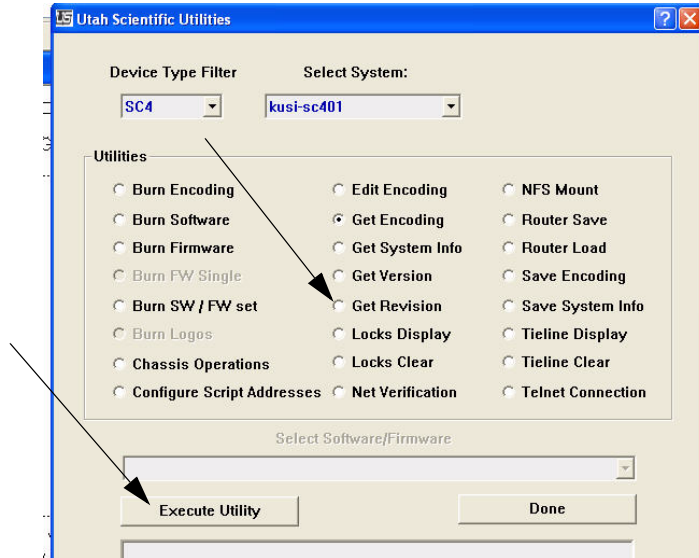

This is an example of the SC-4’s firmware readback. This will be similar to all devices that this application is performed with.

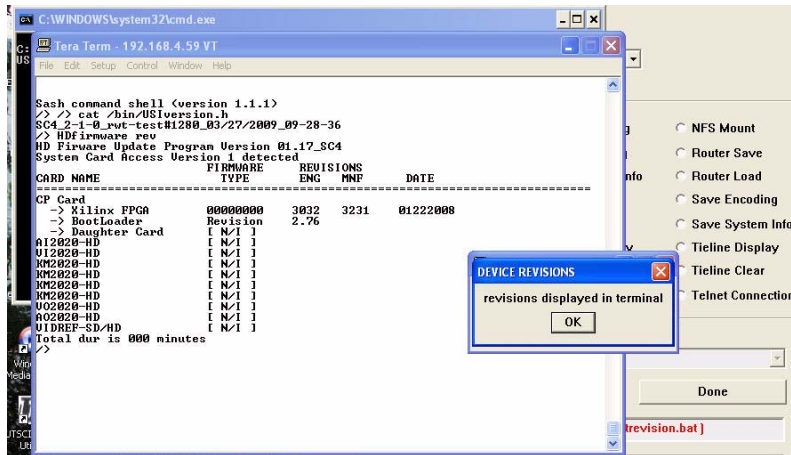



In order to see the firmware version for the SC-4, SC-400, SCVX-400, ESI, and MX-Lator, you will need to click on the terminal window and type mem, then click Return (to activate the >>). Do not click the OK button.

```

U02020-HD          [ N/I ]
A02020-HD          [ N/I ]
UIDREF-SD/HD      [ N/I ]
Total dur is 000 minutes
/> mem
*****
*           Utah Scientific           *
*           Hardware Test Utility     *
*                                     *
* Use "?" for help                    *
* Motorola M5307C3 boot Version: U1.1 *
*****
>>

```

Next, type rx at the prompt, followed by Return.

```

* Motorola M5307C3 boot Version: U1.1 *
*****
>>rx
48000000: abcd1234 00000000 30323231 01222000      4  0221 "
48000010: 00000000 86000000 00000000 00000000
48000020: 00000000 00000000 00000000 80000000
48000030: 00000001 86000000 00000000 00000000
48000040: 00000000 00000000 00000000 80000000
48000050: 000000fc 000000f8 000000fa 00000000
48000060: 000000ff 000000ff 000000ff 80000000
48000070: 99999999 00000000 00000000 00000000
48000080: 00000000 00000000 0000009f 00000000
48000090: 00000004 00000001 00000004 00000055
480000a0: 00000010 0000025e 00334848 80000000      3HI  U
480000b0: 00000000 00000000 00000080 00010081
480000c0: 00040083 00000001 00003a98 00010087
480000d0: 00000000 00000086 00000000 00000000
480000e0: 00000000 00000000 00000000 80000000
480000f0: 00000000 86000000 00000000 00000000
>>

```

In this example, the 0221 refers to the firmware version, which you will compare with the same number found in the table on page 4-16.

Each device listed will contain their own firmware revision (number).

## Additional Update and Installation

To verify the proper firmware version on the remaining devices, note the date column, then compare with the table located on page 4-16.

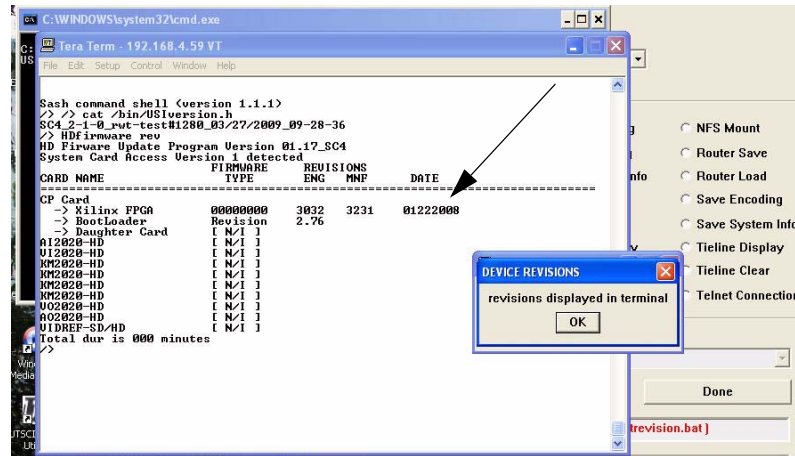

The remaining devices include; MC-40, MC-400, MCP-40, MCP-400, SD/HD-2020, and the MCP-2020.

Repeat steps 1-5 (above) for each device in your system.



## Upgrading the Device Firmware/Software Using the New Utility

1. Launch the Utsci Installation Utility and on the main screen click the Utilities button.

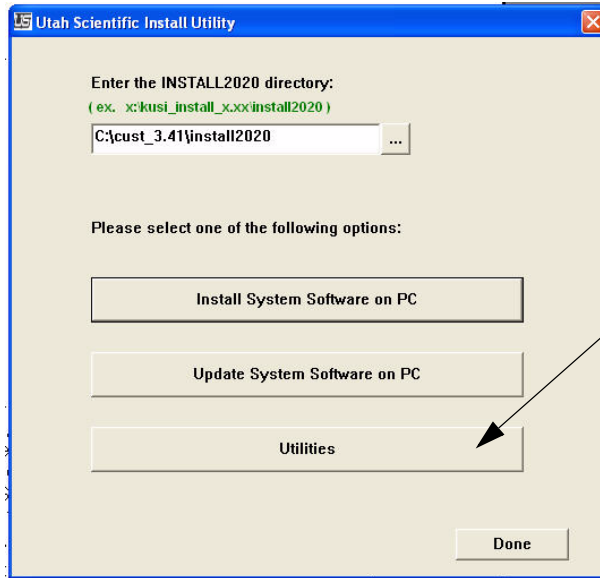

Note: if you do not already have the NFS Server running it will not allow you to proceed and you will get an error box indicating this.

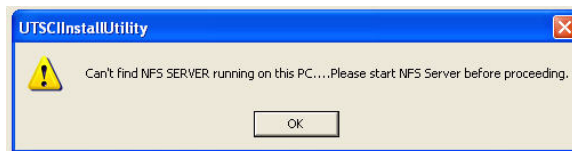

2. Drop down the selection list for the Device Type Filter and select each device type one by one such as the SC4.

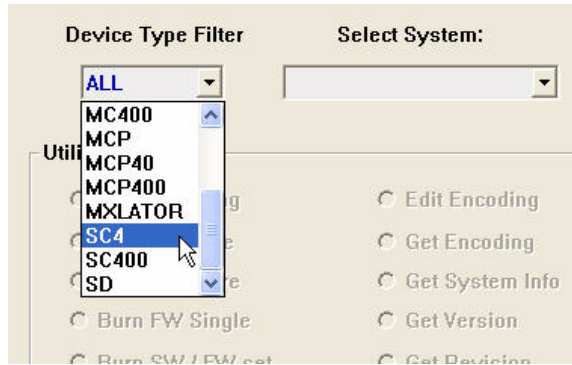

Keep in mind that the devices labeled CBSHD, ESI, HD, MCP and SD are all MC2020 products. All the other devices are self descriptive of what they represent.

3. Drop down the selection list for the system you will be retrieving the encoding from.

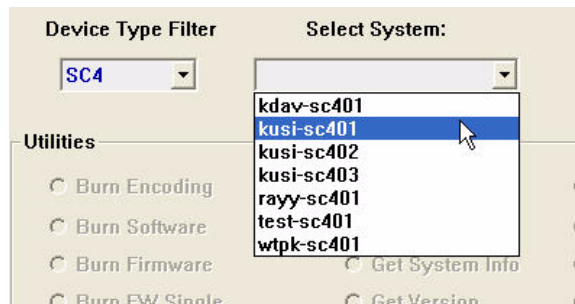

(Note: this will only display the system folders created above for that device type. I.e. – if you created a folder called KUSI and a device type for an SC4 then the list will only display a folder called kusi-sc401.)



4. All of the possible utilities for the selected device will be activated. You will need to enter the IP addresses for this device and the config pc you are using this application from.

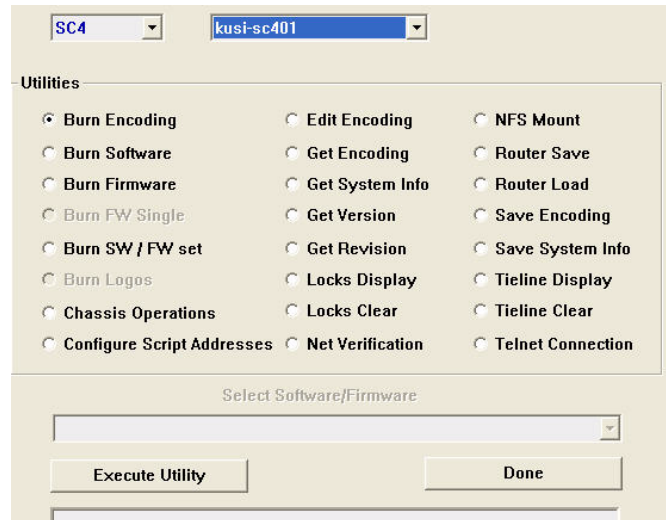

Unless you change the IP address in the device, this will be the only time you will need to set the addresses for the script files to function properly. Choose the “Configure Script Addresses” and then click on the “Execute Utility” button.

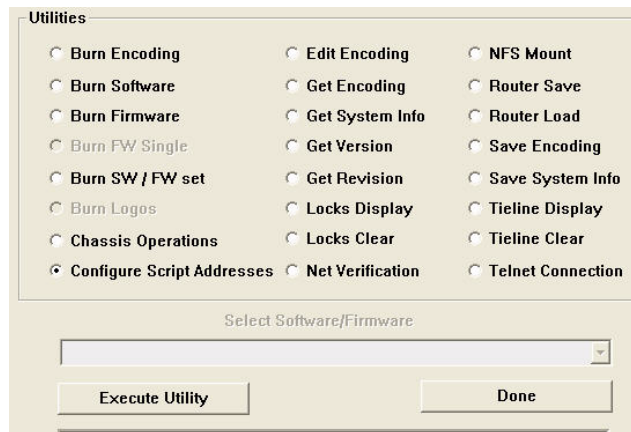

This will prompt you to enter the correct pc address first followed by the correct device address. It will retain this for all remaining utility functions.

*Note: If your device firmware is current, there is no need to perform the Burn Firmware update. However the software update must be performed. If your system does require a firmware upgrade, you will perform the same procedure as shown below for updating the software, but you will select the Burn Firmware button instead.*



**Firmware upgrades will take anywhere from 5 to 45 minutes, depending on the device type. Software typically last less than 5 minutes.**

5. Next choose the “Burn Software” button and then select the current version from the drop-down menu (shown). Then click the Execute

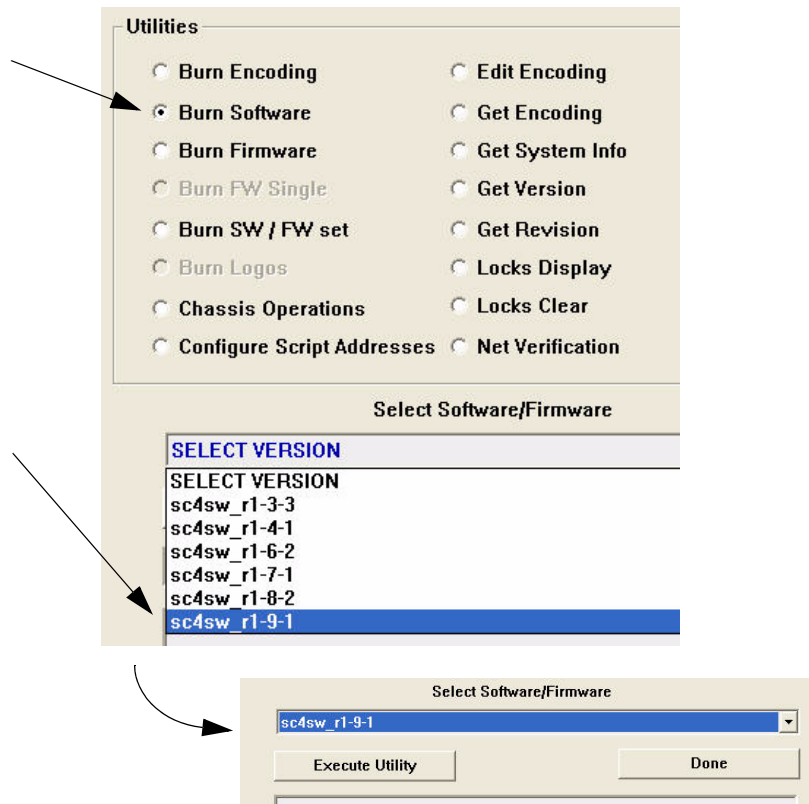

button.





#### Batch File Selection (Utility Help List)

---

If your device requires both firmware and software, select **Burn SW/FW** set, which will perform both upgrades consecutively.

Note: All software versions for each device listed in the drop-down menu will contain "xxxsw\_r3-00" or newer, and is required in order to use this utility, the U-CON, and MC-Config applications.

Repeat steps 1-5 (above) for each device in your system.





# 5

## The Utah Scientific SYSLOG Program

This Section contains the following:

Installing the System Logging Application .....	5-2
Running the Application .....	5-3
System Logging Menu .....	5-3
Keyboard Control Commands .....	5-3
Default Log Server Name and Location .....	5-5
Customizing Log Server Name .....	5-6
Logging Results .....	5-7
Parsing the data from the logs .....	5-8
Parsing (filtering) the log using key words .....	5-8
Master Control Keywords .....	5-11
SC4/SC400/SCX400 Router Controller Keywords .....	5-13
Usage Overview .....	5-13
TAS Protocol Notes (Automation) .....	5-14
Log Analyzer Application .....	5-17
Launching the Log Analyzer Application .....	5-17
Using the Application .....	5-17
Example of Problem with Two Buttons Pressed Simultaneously .	5-20
Operator presses 2 buttons at the same time .....	5-20
Example of Auto Take Being Pressed .....	5-25
Automation Company Details for 2020/400 .....	5-28
Automation Company Details for SC-4/SC-400/SCX-400 .....	5-29
DEBUG2020 UTILITY .....	5-29

## Installing the System Logging Application

1. Locate the system CD and open the folder called Install2020.
2. Open the folder called release-syslog.
3. Double click the batch file called setup.bat to install the system logging application. The folder usilogs will be added to the C: drive with the following sub folders along with this “How To” application guide.

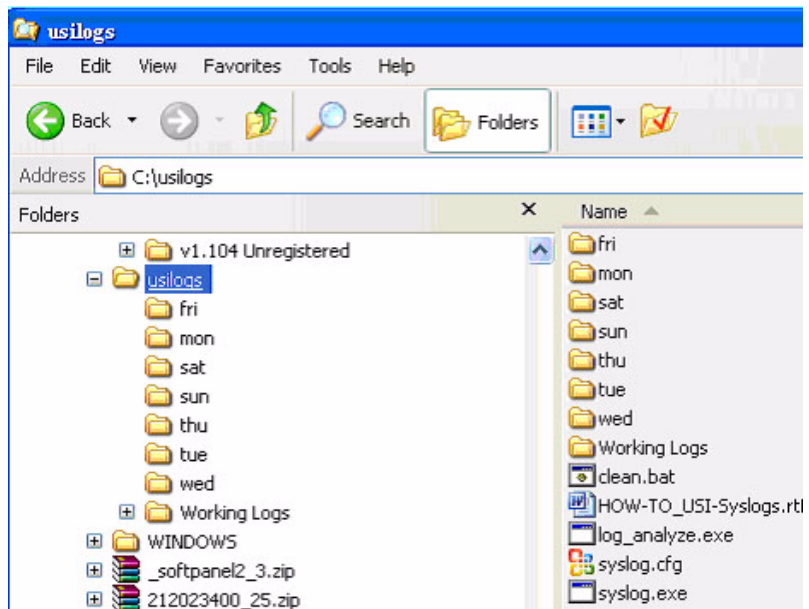

Figure 5-1. System Logging folder



## Running the Application

Note: Only one instance of the syslogs application can run at a time.

Go to c:/usilogs and double click the syslog.exe program file. You will see the following window open and within a few seconds data numbers should begin counting up at the right as noted by the white arrow (Figure 5-2).

The more devices that are on the network and setup for logging as well as how much activity is going on with all the devices, the quicker this number will progress.

### System Logging Menu

There are three menu items that can be used in the logging application. Press the Enter key to see these items. The following menu will appear. (Figure 5-2)

#### Keyboard Control Commands

-> D – Display Clients I – Displays IP addresses

-> S – Displays Statistics

-> X – Exit application

1. Press the letter S and you will see these general statistics. (Figure 5-2)
  - a. Main logging server ID – (default is USI\_SYSLOG01)
  - b. Start of application time and current computer time
  - c. Bytes being logged per hour, minute and second
  - d. Current log being generated
2. Press the letter D and you will see the names of the devices that are active on the network. Note: these names will only show up when the Log Server name in the device config file matches the name of the Log Server. See next section for details. (Figure 5-2)

The names in this section are assigned in the following locations.

  - a. SC4 name is the name assigned to the chassis. To change this name, refer to the System Installation Guide section D using chassis commands.

- b. B.All Master Control device names are the system name found at the top of the device configuration file. NOTE: If you modify the system name in the MC card or CPU then you must put this exact name in the chassis connection table found in the MCP control panel being used for that card or CPU. I.e. if you had an MC400 card that you change the system name in then you must go to the MCP400 file and put the same name in its table.
3. Press I to see the active device IP addresses. Same note applies as step 2 above.

```

C:\usilogs\syslog.exe
processing config file
Starting Logserver
Logserver Running
Bringing up NMS Server with NMS ID of [USI_SYSLOG01]
NMS Server Running
Logserver [log is c:\usilogs\tue\syslog17.log cmd count 1518
] is not currently supported

#####
Keyboard Control Commands
-> D - Display Clients I - Display IP Addresses
-> S - Display Statistics
-> X - Exit
Logserver [log is c:\usilogs\tue\syslog17.log cmd count 1522
#####
Syslog Using [USI_SYSLOG01] as logserver network ID
Syslog Started on 04/28/2009 17:45:12
Current Time is 04/28/2009 17:47:34
Running for 0 days 0 hours 2 minutes
Command Statistics
Type Total msg/Hour msg/min msg/sec
Logserv 1522 1522 761 10
Logserver [log is c:\usilogs\tue\syslog17.log cmd count 1524
#####
**** LOGSERVER Displaying active clients ****
-> SLOT Name Msg Count tout Connect Time
-> 000 [USI ] 794 0 04/28/2009 17:45:18
-> 001 [SERU-MCP40 ] 543 8 04/28/2009 17:45:21
-> 002 [SERU-SC400 ] 127 7 04/28/2009 17:45:23
-> 003 [CASEY ] 15 8 04/28/2009 17:45:23
-> 004 [UTAH-SC4 ] 15 8 04/28/2009 17:45:23
-> 005 [KFYR-MCP01 ] 15 7 04/28/2009 17:45:23
-> 006 [JEEP ] 15 7 04/28/2009 17:45:23
Logserver [log is c:\usilogs\tue\syslog17.log cmd count 1527
#####
**** LOGSERVER Displaying client addresses ****
-> SLOT IP Name
-> 000 192.168.6.154 [USI ]
-> 001 192.168.6.161 [SERU-MCP40 ]
-> 002 192.168.6.150 [SERU-SC400 ]
-> 003 192.168.6.180 [CASEY ]
-> 004 192.168.6.152 [UTAH-SC4 ]
-> 005 192.168.6.158 [KFYR-MCP01 ]
-> 006 192.168.6.50 [JEEP ]
  
```

Figure 5-2. Active Log Server Display



### Default Log Server Name and Location

In order for the logging to function properly there is a default name of USI\_SYSLOG01 that has been placed in each device config file. They are found in the following sections:

SC4/SC400/SCX400 – The logging name is found in the 6th section from the top of the config file and looks like this:

```
#####
#####
# SYSLOG Server Name
[SYSLOG_NAME]
# NAME
  USI_SYSLOG01
#####
#####
```

MC2020/MC400/ MC40 – The logging name is found in the MISC Start section which is the first section from the top of the config file after the system name info and looks like this:

```
AUDIO_CHANNELS:          @00FF
AUDIO_DIM_ADJUST:      @-15
VIDEO_MIX_POSITION:    @08
KEY_LEVEL_RESET_MASK:  @0f
KEY_LEVEL_XFER_MASK:   @00
TRANS_SPEED_FAST:     @30
TRANS_SPEED_MEDIUM:    @60
TRANS_SPEED_SLOW:     @120
SYSLOG_SERVER_ID:      @USI_SYSLOG01
#AUX_OUT_XPOINT_SEL:   @PVW
```

MCP2020/MCP400/MCP40 - The logging name is found in the MISC Start section which is the first section from the top of the config file after the system name info and looks like this:

```
#PASSWORD_MAINT:      NOT CONFIGURED
SYSLOG_SERVER_ID:     @USI_SYSLOG01
```

#AUDIO\_POT\_LINKED: NOT CONFIGURED

### **Customizing Log Server Name**

Even though the default log server name is USI\_SYSLOG01 this can be changed. You will need to locate the device config file in the c:\usi\device folder\encode directory and then go to the section shown above for that device and only change the name. If there is an @ sign it must remain as it is. The next thing is to go to the c:\usilogs folder and open the syslog.cfg file and go to the very bottom line which looks like this.

```
#####
```

```
#LOGPATH, c:\usilogs
```

```
#SERVNAME, SYSLOG_RT01
```

You will need to remove the # sign from the SERVNAME line and then change the SYSLOG\_RT01 named to the desired name you are changing it to.

If you wanted to separate the different devices and log only a specific device at one time then edit this syslog.cfg file and put all the device names in the list, but only remove the # sign from the line that you will be logging.

For example; if you had two channels of master control and wanted to separate these and log only the events on channel 2 then this may be what you would want to do.

1. Change the name in the config files for both channels to something of your choice like, MC\_CH1 and MC\_CH2. Like the following.

```
SYSLOG_SERVER_ID: @MC_CH1 (Put this in ch1 config)
```

```
SYSLOG_SERVER_ID: @MC_CH2 (Put this in ch2 config)
```

2. Next add both names in the syslog.cfg and remove the # sign from the MC\_CH2 line like the following.

```
#####
```

```
#LOGPATH, c:\usilogs
```

```
#SERVNAME, MC_CH1
```

```
SERVNAME, MC_CH2
```





3. Launch the syslog.exe program from c:\usisyslogs and watch for the data to start in the dos window and that the log has been created in the day of the week as described in the sections above.

### Logging Results

While the logging application is running it will open a file in the day of the week for the hour (24 hour time base) that the computer is currently on. The folders for each day of the week are located in the c:\usilogs directory. As long as the logging application is running it will close each log and start a new one at the top of each hour. I.e. if the logging application was ran between 11:15am and 2:35pm on a Tuesday then in the c:\usilog\Tuesday folder you would see 4 log files that had been generated. They would be called syslog11.log, syslog12.log, syslog13.log and syslog14.log. The numbers represent the hour the log was running in 24 hour time base (below).

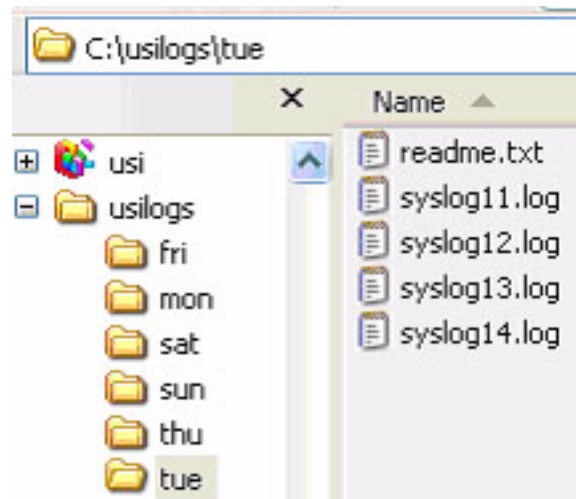

Figure 5-3. Logging Results

### ***Parsing the data from the logs***

Note: due to the complexity of the logs, parsing through and looking for the problem through the extracted logs is not expected to be used from the customer and can be sent to Utah Scientific Customer Service if desired using the [service@utsci.com](mailto:service@utsci.com) email address. However, if you wish to attempt parsing through the log then proceed with the next section on how to do this.

**\*\*Before sending logs to Utah Scientific make sure you do the following:**

1. Write a detailed description of the problem that is happening
2. Note the system name of the device that is having the problem.
3. Note the time of the occurrence as close as possible.
4. Send the proper log file for that hour. (See details in above sections)

### ***Parsing (filtering) the log using key words***

1. Locate the log file that has been created in the day of the week folder. If the log is still running for the hour you wish to look at it and then copy and paste it in the same folder.
2. Copy the log file from step 1 and paste it into the `c:\usilogs\working logs` folder.
3. Right click on the `parse.bat` file in the `c:\usilogs\working logs` folder and select edit from the menu. You will see a similar batch file line to something like this example.

```
la syslog15.log /multi /grep gpi > gpi.txt
```

4. You will also see the following items which are simply in the file as descriptions for each item in the batch file. The REM is placed before each description so that it can be in the file without trying to use that line allowing you to still read it.

```
REM la = log analyze program
```

```
REM *.log = file to look in
```



REM /multi = attribute allowance for file name search

REM /grep = search command

REM PASMLT = this is the item to search for

REM > = pipe to this file name

REM \*.txt = new file name to be given for search results

5. You will need to edit the batch file line with the information from your log. The way it works is it will use your log file, search for an item in it and then create a new file with only the information found from the search. This is what is referred to as parsing.
6. In the batch file line change the syslog15.log to the name of the file you placed in the working folder from step 2.
7. Change the item called gpi in the batch file line to whatever item name you would like to search for that is found in the log file. Some keywords are listed in the following sections.
8. Change the name gpi.txt in the batch file line to whatever name you would like to call the new file that will be created with only the filtered items from step 7.
9. Save and Close the batch file and then double click it to run the batch file with your changes. You should see the new file name appear in the same working logs folder.
10. Double click the new file from step 9 to see the results of your search. If nothing was found then you will see something similar to this readout.

Overriding processing mode to [MULTIPLE FILES]

Setting to grep Mode

Overriding grep text to [gpi]

Using cfg file [la.cfg] outputfile is NULL

Process name [DEMOROOM-SD01], dst [dst 0130], level [lev 00]

grep text is [gpi]

multi is [ON] summary is [OFF]

Analyze Mode is GREP

Couldn't find matching file for [syslog15.log]



### Master Control Keywords

The following are examples of words you can search for within the log for troubleshooting purposes.

Name	Description
TAS-PC ROUTER:NUMERIC	This is a good message followed by information about automation. This is the command to show automation takes that happen which will show the source index to the pst bus 01.
PANEL:PRC() (1)grp	Take commands from a PANEL in the CHASSIS (this is a good cmd) button presses on MCP panel.
Dst 0	PGM bus being switched
Dst 1	PST bus being switched
grp 01	indicates the PGM Router button group -----[xxxxxxx]
fcn	indicates the button # starting from 0 -----[xxxxxxx]
st 01	indicates the button was pressed
st 00	indicates the button was released (not important info)
PASMLT	This identifies a command sent by a Master Control to switch a router.
PASMLS	This identifies a command received by a Master Control showing an output was switched.
GPI	This is logged when a Master Control detects activity on the GPI interface
MACRO	This is logged when a Master Control Macro Playback engine performs an action.
EAS	This is the first part of any command a Master Control logs that pertains to EAS Activity.

## The Utah Scientific SYSLOG Program

---

TAS	This is logged when a Master Control Automation interface performs various actions. The level of log messages can be varied using the debug control interfaces.
send Heartbeat	This command is logged when a Master Control processes a command to verify connection to another Ethernet device.
rxed Heartbeat	This command is logged when a Master Control processes a command from another Ethernet device wishing to verify connectivity.
HWLOG	This command is to show sync issues

```
11713 08:36:02 [MC-RAIAUXREG ] - GRP 001000 ID 000002 PRI INFO 08322501 TRANS: ~TC~08322501
HWLOG:SYNC sid 8 old 0x00d700d7 new 0x00d900d9
11723 08:36:03 [MC-RAIAUXREG ] - GRP 001000 ID 000002 PRI INFO 08322606 TRANS: ~TC~08322606
HWLOG:SYNC sid 9 old 0x00d700d7 new 0x00d900d9
11725 08:36:03 [MC-RAIAUXNAZ ] - GRP 001000 ID 000002 PRI INFO 19191919 TRANS: ~VD~13739389
HWLOG:SYNC sid 8 old 0x00710071 new 0x00730073
11734 08:36:04 [MC-RAIAUXREG ] - GRP 001000 ID 000002 PRI INFO 08322712 TRANS: ~TC~08322712
HWLOG:SYNC sid 2 old 0x00d700d7 new 0x00d900d9
11737 08:36:05 [MC-RAIAUXNAZ ] - GRP 001000 ID 000002 PRI INFO 19191919 TRANS: ~VD~13739450
HWLOG:SYNC sid 9 old 0x00710071 new 0x00730073
```



### SC4/SC400/SCX400 Router Controller Keywords

**Note:** *These are only examples of a few words you can search for in the log to see if you can determine what the problem may be.*

Name	Description
SCP take	This is logged when a controller detects a command from a UNET based control panel to switch the router.
RCP4 take	This is logged when a controller processes a command from a ETHERNET based control panel utilizing the RCP3 command protocol.
UTAH router take	This is logged when a controller sends a command to a physical router device to modify it's crosspoint map. This is equivalent to a MX bus command.
Tieline connection	This is logged when a controller processes a command which uses a tieline to complete the switch request.
Tieline disconnected	This is logged when a controller processes a command which places a tieline back into the free pool. This means no other destinations are using the source this tieline was providing.

### Usage Overview

System Components	SC4, SD MC2020, HD MC2020, MXLATOR, MC400, MCP2020, MCP400
-------------------	--

### ***TAS Protocol Notes (Automation)***

The following example came from a system using TAS\_Rev2. Need to search for TAS\_REV2 and then look for the three lines of info received from the serial port. The following is the description of the protocol. Master control uses the pst video and audio when switching and to determine if the protocol is REV2 you will see the second byte on the pst video and audio lines change in hex which is the source index number found in the SC4.

HEADER (first 6 bytes)01 01 00 2C 35 02  
NOTHING (next 10 bytes)00 00 00 00 00 C0 00 00 00 C0  
PGM VID (next 3 bytes)FF FE FE  
PGM AUD (next 3 bytes)FF FE FE  
PST VID (next 3 bytes)00 01 FE (second byte used is REV2 – when changing source this number will change in hex)  
PST AUD (next 3 bytes)00 01 FE (second byte used is REV2 – when changing source this number will change in hex)  
(these remaining bytes are for aux, keyers, etc.) FF FE FE FF FE FE FF  
FE FE FF FE FE FE FE FE FE FE 80 FE 00 FE 02 FE 03 3B 04

15:17:41 [KSHB-SD01 ] - GRP 001000 ID 000002 PRI INFO  
19191919 PANEL: ~VD~00070887 TAS: Rxed good event msg stack  
location 00 PGM V fffe A

15:54:02 [KSHB-SD01 ] - GRP 001000 ID 000002 PRI INFO  
19191919 PANEL: ~VD~00201594 TAS\_AUTO\_SEND 00 00 00 00 00  
00 00 00 00 20 00 00 20 00 FF FF 00 FF FF 00

15:54:02 [KSHB-SD01 ] - GRP 001000 ID 000002 PRI INFO  
19191919 PANEL: ~VD~00201594 TAS\_AUTO\_SEND 00 00 00 0C 88  
21 11 20 C2 01 FE FE 00 00 00 03 B4 04

15:54:02 [KSHB-SD01 ] - GRP 001000 ID 000002 PRI INFO  
19191919 PANEL: ~VD~00201605 TAS\_REV2\_RECV 01 01 00 2C 31  
02 00 00 00 00 00 C0 00 00 00 C0 FF FE FE FF





15:54:02 [KSHB-SD01 ] - GRP 001000 ID 000002 PRI INFO 19191919  
(pst video) PANEL: ~VD~00201605 TAS\_REV2\_RECV FE FE 00 9A  
FE  
(pst video) 00 9A FE FF FE FE FF FE FE FF FE FE FF FE FE  
15:54:02 [KSHB-SD01 ] - GRP 001000 ID 000002 PRI INFO 19191919  
PANEL: ~VD~00201605 TAS\_REV2\_RECV FE FE FE FE 80 FE 00 FE 02  
FE 03 69 04  
15:54:02 [KSHB-SD01 ] - GRP 001000 ID 000002 PRI INFO 19191919  
PANEL: ~VD~00201605 TAS: Rxed good event msg stack  
(TAS rxed good will show this) location 00 PGM V fffe A fffe PST V 9a A 9a  
15:54:02 [KSHB-SD01 ] - GRP 001000 ID 000002 PRI INFO 19191919  
PANEL: ~VD~00201605 TAS: ---- TR Type fe Rate 02  
15:54:02 [KSHB-SD01 ] - GRP 001000 ID 000002 PRI INFO 19191919  
PANEL: ~VD~00201605 TAS-PC:Event - Processing Event Command 01  
15:54:02 [KSHB-SD01 ] - GRP 001000 ID 000002 PRI INFO 19191919  
ROUTER: ~VD~00201605 MAXTIME\_PIPE PANEL 00000414  
15:54:02 [KSHB-SD01 ] - GRP 001000 ID 000002 PRI INFO 19191919  
ROUTER: ~VD~00201605 MAXTIME\_PROCESS\_PIPES() 531  
15:54:02 [KSHB-SD01 ] - GRP 001000 ID 000002 PRI INFO 19191919  
PANEL: ~VD~00201605 PANEL:PRC() Send RTR Take Src [] Dst 1 lev 0000  
  
15:54:02 [KSHB-SD01 ] - GRP 001000 ID 000002 PRI INFO 19191919  
PANEL: ~VD~00201606 MAXTIME\_GENERAL proc pan 00014651  
15:54:02 [KSHB-SD01 ] - GRP 001000 ID 000002 PRI INFO 19191919  
PANEL: ~VD~00201606 MAXTIME\_GENERAL prpan times [07809701]  
[07810663] [07810589] [07810609] [0781064  
15:54:02 [KSHB-SD01 ] - GRP 001000 ID 000002 PRI INFO 19191919  
PANEL: ~VD~00201606 needlampUpdate can't transflag 0 machineflag 0  
15:54:02 [KSHB-SD01 ] - GRP 001000 ID 000002 PRI INFO 19191919  
TRANS: ~VD~00201607 MAXTIME\_PIPE PANEL 16178 PRd 0000  
15:54:02 [KSHB-SD01 ] - GRP 001000 ID 000002 PRI INFO 19191919  
PANEL: ~VD~00201607 needlampUpdate can't transflag 0 machineflag 1

15:54:02 [KSHB-SD01 ] - GRP 001000 ID 000002 PRI INFO  
19191919 PANEL: ~VD~00201607 needlampUpdate can't transflag 0  
machineflag 1

15:54:02 [KSHB-SD01 ] - GRP 001000 ID 000002 PRI INFO  
19191919 ROUTER: ~VD~00201609 ROUTER:Numeric take in 154, out  
01, lev 0000

15:54:02 [KSHB-SD01 ] - GRP 001000 ID 000002 PRI INFO  
19191919 ROUTER: ~VD~00201609 PASMLT() sending take in 154 out  
069, lev 0x0003

15:54:02 [KSHB-SD01 ] - GRP 001000 ID 000002 PRI INFO  
19191919 TRANS: ~VD~00201611 UpdateAudInput el Time 0132

15:54:02 [KSHB-SD01 ] - GRP 001000 ID 000002 PRI INFO  
19191919 ROUTER: ~VD~00201611 PASMLS(1) sending in 154 (NBC  
RF) out 1 lev 0x0000 txtidx 0 to panel



## Log Analyzer Application

This application will simplify the sorting of the logs as it will allow for searching all or part of words and phrases once the logs are retrieved. The Log Analyzer will also perform all of the filtering tasks (referred to above) in the manual operation of *sorting through* the logs.

### Launching the Log Analyzer Application

1. Locate the folder called 2009-06-01-LogAnalyzer-1.4 found in c:\usilogs on open it.
2. Double click on the 'loganalyzer.exe' to launch the program.

### Using the Application

The base directory found in the upper right corner will default to c:\usilogs, which is the location where each folder for the days of the week reside. As explained in an earlier discussion, the logging application saves each log for every hour and places the log in the folder for that day of the week.

1. Click the target day of the week where the desired log to view is found. At this time all of the hours that contain logs will light up, as seen in the figure below. In this case, there is only one log file for the 1700 hour (or 5:00) designation.

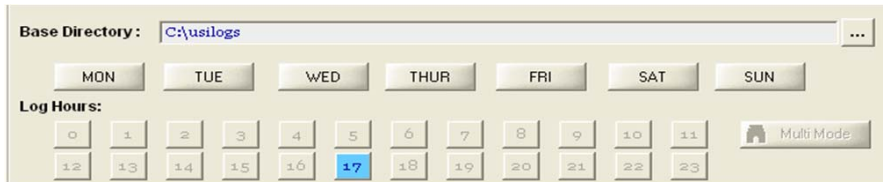

- Next, click [on] the hour you want to analyze. In this case it would be the number 17. At this time all of the data for that log will appear in text as seen in the figure below.

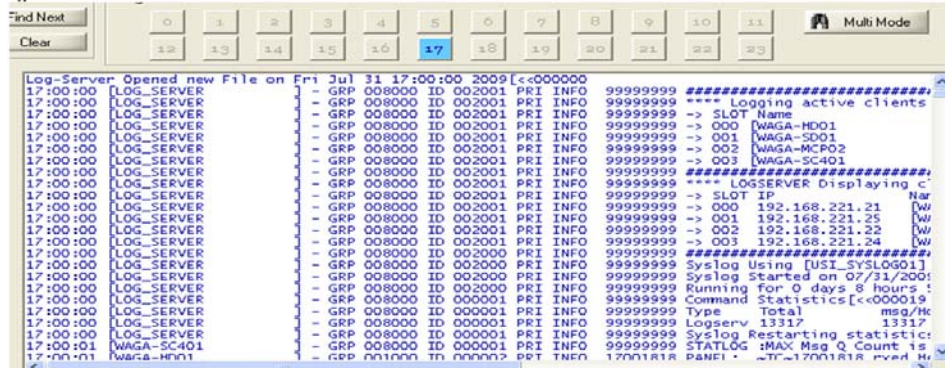

- To filter just the information for any given device, click the drop down arrow in the section at the middle left titled 'Devices Filter', then click on any or all of the devices found. These are the names located in the log file of all actively logged devices. (See picture example below.) Now click the 'Filter' button in the upper right corner. This will place the text in the table to the right that corresponds to the device you want to filter.





- Next you will need to click the desired filters from the drop down menu in the 'Message Filter' window. There are three areas of messages currently active in this section. They are the 'System Controller', 'Master Control', and Master Control Panel'. Click the plus sign next to these items and select the individual items that you would like to filter. Now click on the 'Filter' button in the upper right corner. This will display any items found in the message text window *only*.



- To search the filtered text at any time for specific items, type the text in the search windows as either specific words or an entire phrase, then click the *Search All* or *Find Next*. You can match the text by case only or whole words by checking the desired box.



To save the text to a location on the computer or another drive click, the 'Multi Mode' button and then select the location to save the text file *to*.

## ***Example of Problem with Two Buttons Pressed Simultaneously***

### ***Operator presses 2 buttons at the same time***

#### Problem

1. Customer thinks the MC2020 put the wrong source on air.
2. Problem occurs around 19:50
3. Customer was very good at providing all the info required to find the problem (see below). This REALLY helped!!!!

#### Procedure

1. Filter the main syslog to separate the SD and MCP info  
log\_analyze syslog19.log /grep MC-RAI1SD /on 19\_sd.txt /q  
log\_analyze syslog19.log /grep MCP02-Rai1 /on 19\_mcp.txt /q

**Note:** *The 19\_xxxx is used so that you can work with more than 1 log file. The 19 shows which hour the data comes from.*

2. Filter all take commands from a PANEL in the CHASSIS  
log\_analyze 19\_sd.txt /grep PANEL:PRC() /on 19\_sd-panel-takes.txt /q
3. Filter all button presses on MCP panel  
log\_analyze 19\_mcp.txt /grep (1)grp /on 19\_mcp-btn.txt /q
4. Open 19\_sd-panel-takes.txt, 19\_mcp-btn.txt
5. Open a new file and copy the contents of the 2 files in the line above to the new file



example

<snip>

```
828 13407 19:52:35 [MCP02-Rai1      ] - GRP 006000 ID 001000 PRI
INFO 00000000 (1)grp 02 fcn 05, st 01 cmdptr 047dd912 *cmdPtr 047db1e8
```

```
831 13428 19:52:36 [MCP02-Rai1      ] - GRP 006000 ID 001000 PRI
INFO 00000000 (1)grp 02 fcn 05, st 00 cmdptr 047dd912 *cmdPtr 047db1e8
```

```
529 7587 19:31:08 [MC-RAI1SD      ] - GRP 001000 ID 000002 PRI INFO
19191919 PANEL: ~VD~04673204 PANEL:PRC() Send RTR Take Src
[PUBB  ] Dst 1 lev 0000
```

```
647 8502 19:34:28 [MC-RAI1SD      ] - GRP 001000 ID 000002 PRI INFO
19191919 PANEL: ~VD~04683179 PANEL:PRC() Send RTR Take Src
[SPOT  ] Dst 1 lev 0000
```

<snip>

6. Remove 1st column of line #'s on left hand side of file. This leaves only the real line numbers from the original syslog file.

example

<snip>

```
13407 19:52:35 [MCP02-Rai1      ] - GRP 006000 ID 001000 PRI INFO
00000000 (1)grp 02 fcn 05, st 01 cmdptr 047dd912 *cmdPtr 047db1e8
```

```
13428 19:52:36 [MCP02-Rai1      ] - GRP 006000 ID 001000 PRI INFO
00000000 (1)grp 02 fcn 05, st 00 cmdptr 047dd912 *cmdPtr 047db1e8
```

```
7587 19:31:08 [MC-RAI1SD      ] - GRP 001000 ID 000002 PRI INFO
19191919 PANEL: ~VD~04673204 PANEL:PRC() Send RTR Take Src
[PUBB  ] Dst 1 lev 0000
```

```
8502 19:34:28 [MC-RAI1SD      ] - GRP 001000 ID 000002 PRI INFO
19191919 PANEL: ~VD~04683179 PANEL:PRC() Send RTR Take Src
[SPOT  ] Dst 1 lev 0000
```

<snip>

7. Highlight the line numbers using a column mark in MED

- Sort the data [File->Edit->Document->Sort). Make sure SORT SELECTION is checked

Now everything is in order and you can see what's going on. Sometimes the panel commands can be below the chassis commands as is the case with this file.

#####

The important lines are:

- Lines 12315 and 12319 show the SD chassis processing 2 take commands from the PGM bus.

The 1st is for SPOT, the 2nd is for PUBB

- Lines 12348 and 12358 show the MCP Panel processing 2 button press commands for the PGM bus.

The 1st is fcn 5 (the 6th button), the 2nd is fcn 4 (the 5th button)

So, the system did what it was asked to do.

**Note:** *The button presses show up later in the log. This is not an error.*

#####

**Note:** *The left hand column of the data below is the line number from the original syslog file.*

#####

12020 19:47:46 [MC-RAI1SD ] - GRP 001000 ID 000002 PRI INFO  
19191919 PANEL: ~VD~04723105 PANEL:PRC() Send RTR Take Src  
[BLACK ] Dst 0 lev 0000

12023 19:47:46 [MCP02-Rai1 ] - GRP 006000 ID 001000 PRI INFO  
00000000 (1)grp 01 fcn 00, st 01 cmdptr 047dd912 \*cmdPtr 047db1e8

12046 19:47:47 [MCP02-Rai1 ] - GRP 006000 ID 001000 PRI INFO  
00000000 (1)grp 01 fcn 00, st 00 cmdptr 047dd912 \*cmdPtr 047db1e8

12293 19:48:36 [MCP02-Rai1 ] - GRP 006000 ID 001000 PRI INFO  
00000000 (1)grp 06 fcn 01, st 01 cmdptr 047dd912 \*cmdPtr 047db1e8





12298 19:48:36 [MCP02-Rai1 ] - GRP 006000 ID 001000 PRI INFO  
00000000 (1)grp 06 fcn 01, st 00 cmdptr 047dd912 \*cmdPtr 047db1e8

### 2 TAKES on PGM 1st is SPOT, 2nd is PUBB

the Dst 0 indicates PGM is being switched

-----[xxxx  
x]

12315 19:48:37 [MC-RAI1SD ] - GRP 001000 ID 000002 PRI INFO  
19191919 PANEL: ~VD~04725666 PANEL:PRC() Send RTR Take Src  
[SPOT ] Dst 0 lev 0000

12319 19:48:37 [MC-RAI1SD ] - GRP 001000 ID 000002 PRI INFO  
19191919 PANEL: ~VD~04725667 PANEL:PRC() Send RTR Take Src  
[PUBB ] Dst 0 lev 0000

### BUTTON presses from MCP panel that made the 2 takes on PGM above

### 1st press is SPOT on PGM (the 6th button)

the grp 01 indicates the PGM Router button group

-----[xxxxxxx]

the fcn 05 indicates the button # starting from 0

-----[xxxxxxx]

the st 01 indicates the button was pressed

-----[xxxxx]

12348 19:48:38 [MCP02-Rai1 ] - GRP 006000 ID 001000 PRI INFO  
00000000 (1)grp 01 fcn 05, st 01 cmdptr 047dd912 \*cmdPtr 047db1e8

### 2nd press is PUBB (the 5th button)

the grp 01 indicates the PGM Router button group

-----[xxxxxxx]

the fcn 05 indicates the button # starting from 0

-----[xxxxxxx]

the st 01 indicates the button was pressed

-----[xxxxx]

12358 19:48:38 [MCP02-Rai1 ] - GRP 006000 ID 001000 PRI INFO  
00000000 (1)grp 01 fcn 04, st 01 cmdptr 047dd912 \*cmdPtr 047db1e8  
### panel button release events (don't care)

the grp 01 indicates the PGM Router button group  
-----[xxxxxxx]

the fcn 05 indicates the button # starting from 0  
-----[xxxxxx]

the st 00 indicates the button was released  
-----[xxxxx]

12361 19:48:38 [MCP02-Rai1 ] - GRP 006000 ID 001000 PRI INFO  
00000000 (1)grp 01 fcn 04, st 00 cmdptr 047dd912 \*cmdPtr 047db1e8

12369 19:48:38 [MCP02-Rai1 ] - GRP 006000 ID 001000 PRI INFO  
00000000 (1)grp 01 fcn 05, st 00 cmdptr 047dd912 \*cmdPtr 047db1e8

13093 19:51:40 [MC-RAI1SD ] - GRP 001000 ID 000002 PRI INFO  
19191919 PANEL: ~VD~04734794 PANEL:PRC() Send RTR Take Src  
[IMX 2] Dst 1 lev 0000

13106 19:51:41 [MCP02-Rai1 ] - GRP 006000 ID 001000 PRI INFO  
00000000 (1)grp 02 fcn 09, st 01 cmdptr 047dd912 \*cmdPtr 047db1e8

13113 19:51:41 [MCP02-Rai1 ] - GRP 006000 ID 001000 PRI INFO  
00000000 (1)grp 02 fcn 09, st 00 cmdptr 047dd912 \*cmdPtr 047db1e8

13242 19:52:08 [MCP02-Rai1 ] - GRP 006000 ID 001000 PRI INFO  
00000000 (1)grp 06 fcn 01, st 01 cmdptr 047dd912 \*cmdPtr 047db1e8

13245 19:52:08 [MCP02-Rai1 ] - GRP 006000 ID 001000 PRI INFO  
00000000 (1)grp 06 fcn 01, st 00 cmdptr 047dd912 \*cmdPtr 047db1e8

13407 19:52:35 [MCP02-Rai1 ] - GRP 006000 ID 001000 PRI INFO  
00000000 (1)grp 02 fcn 05, st 01 cmdptr 047dd912 \*cmdPtr 047db1e8

13408 19:52:35 [MC-RAI1SD ] - GRP 001000 ID 000002 PRI INFO  
19191919 PANEL: ~VD~04737551 PANEL:PRC() Send RTR Take Src  
[SPOT ] Dst 1 lev 0000

13428 19:52:36 [MCP02-Rai1 ] - GRP 006000 ID 001000 PRI INFO  
00000000 (1)grp 02 fcn 05, st 00 cmdptr 047dd912 \*cmdPtr 047db1e8



**Example of Auto Take Being Pressed**

Date: 03-02-2009

Path: c:\d\customer\wisc\2009-03-02\_mc4000meltdown\findings.txt

Desc: SUMMARY OF MELTDOWN @ WISC (customer description)

Files: syslog06.log, wisc-mc4001.conf (supplied by customer)

```
-----
#####
#####
-----
```

Issue: Panel started toggling between 2 different sources @ 2 second intervals

Result: Normal operation (no system bugs)

Info: Operator turned on the AUTO TAKE @ 6:28:19 (LINE #1892 in syslog06.log)

```
-----
#####
#####
-----
```

Break down of log commands from syslog06.log

1. This excerpt from panel.txtfile
2. generated by:

la syslog06.log /grep "USI-MCP40\_01 " /on panel.txt /q

```
-----
Here's the operations leading up to AUTO TAKE
```

### NOTE ###

This workup is specific to MCP40 control panel!!!!

#####

LEGEND

BUTTON PRESS [EAS LOCAL] MAIN MENU button 7  
BUTTON RELES [NKK 06] LOCAL btn released  
BUTTON PRESS [NKK 07] buttons start @ 0 so this is button 8  
BUTTON PRESS [NKK 07]  
BUTTON PRESS [NKK 07]  
BUTTON PRESS [NKK 01] button 2 on NKK buttons

-----  
1839 06:28:06 [USI-MCP40\_01 ] (1)grp 46 fcn 01, st 01 pbtn 200  
cmd 00000000 \*cmd 00000000 BUTTON PRESS [EAS LOCAL]  
1842 06:28:06 [USI-MCP40\_01 ] (1)grp 50 fcn 06, st 00 pbtn 06  
cmd 04b2bc52 \*cmd 04b283d6 BUTTON RELES [NKK 06]  
1843 06:28:06 [USI-MCP40\_01 ] (1)grp 46 fcn 01, st 00 pbtn 200  
cmd 00000000 \*cmd 00000000 BUTTON RELES [EAS LOCAL]  
1847 06:28:07 [USI-MCP40\_01 ] (1)grp 50 fcn 06, st 01 pbtn 06  
cmd 04b2bc52 \*cmd 04b283d6 BUTTON PRESS [NKK 06]  
1848 06:28:07 [USI-MCP40\_01 ] (1)grp 46 fcn 01, st 01 pbtn 200  
cmd 00000000 \*cmd 00000000 BUTTON PRESS [EAS LOCAL]  
1851 06:28:08 [USI-MCP40\_01 ] (1)grp 50 fcn 06, st 00 pbtn 06  
cmd 04b2bc52 \*cmd 04b283d6 BUTTON RELES [NKK 06]  
1852 06:28:08 [USI-MCP40\_01 ] (1)grp 46 fcn 01, st 00 pbtn 200  
cmd 00000000 \*cmd 00000000 BUTTON RELES [EAS LOCAL]  
1857 06:28:09 [USI-MCP40\_01 ] (1)grp 50 fcn 06, st 01 pbtn 06  
cmd 04b2bc52 \*cmd 04b283d6 BUTTON PRESS [NKK 06]  
1858 06:28:09 [USI-MCP40\_01 ] (1)grp 46 fcn 01, st 01 pbtn 200  
cmd 00000000 \*cmd 00000000 BUTTON PRESS [EAS LOCAL]  
1861 06:28:10 [USI-MCP40\_01 ] (1)grp 50 fcn 06, st 00 pbtn 06  
cmd 04b2bc52 \*cmd 04b283d6 BUTTON RELES [NKK 06]  
1862 06:28:10 [USI-MCP40\_01 ] (1)grp 46 fcn 01, st 00 pbtn 200  
cmd 00000000 \*cmd 00000000 BUTTON RELES [EAS LOCAL]

#####

Line 1862 establishes the MCP-40 panel was on the MAIN menu as that is the only place EAS LOCAL is available



```
#####  
1865 06:28:10 [USI-MCP40_01 ] (1)grp 50 fcn 07, st 01 pbtn 07 cmd  
04b2bc52 *cmd 04b283d6 BUTTON PRESS [NKK 07] [MAINT  
SCREEN SELECT]  
1867 06:28:10 [USI-MCP40_01 ] (1)grp 50 fcn 07, st 00 pbtn 07 cmd  
04b2bc52 *cmd 04b283d6 BUTTON RELES [NKK 07]  
1872 06:28:12 [USI-MCP40_01 ] (1)grp 50 fcn 07, st 01 pbtn 07 cmd  
04b2bc52 *cmd 04b283d6 BUTTON PRESS [NKK 07] [MAINT  
SCREEN MORE, goto page 2]  
1874 06:28:12 [USI-MCP40_01 ] rxd Heartbeat cmd from dev  
[192.168.17.6]  
1875 06:28:12 [USI-MCP40_01 ] (1)grp 50 fcn 07, st 00 pbtn 07 cmd  
04b2bc52 *cmd 04b283d6 BUTTON RELES [NKK 07]  
1877 06:28:13 [USI-MCP40_01 ] (1)grp 50 fcn 07, st 01 pbtn 07 cmd  
04b2bc52 *cmd 04b283d6 BUTTON PRESS [NKK 07] [MAINT  
SCREEN MORE, goto page 3]  
1879 06:28:13 [USI-MCP40_01 ] (1)grp 50 fcn 07, st 00 pbtn 07 cmd  
04b2bc52 *cmd 04b283d6 BUTTON RELES [NKK 07]  
1881 06:28:14 [USI-MCP40_01 ] (1)grp 50 fcn 07, st 01 pbtn 07 cmd  
04b2bc52 *cmd 04b283d6 BUTTON PRESS [NKK 07] [MAINT  
SCREEN MORE, goto page 1]  
1883 06:28:14 [USI-MCP40_01 ] (1)grp 50 fcn 07, st 00 pbtn 07 cmd  
04b2bc52 *cmd 04b283d6 BUTTON RELES [NKK 07]  
1888 06:28:17 [USI-MCP40_01 ] STATLOG :MAX Msg Q Count is 8  
1890 06:28:17 [USI-MCP40_01 ] STATLOG :Current Que Stats hp 465  
tp 464 cnt 1  
#####  
1892 06:28:19 [USI-MCP40_01 ] (1)grp 50 fcn 01, st 01 pbtn 01 cmd  
04b2bc52 *cmd 04b283d6 BUTTON PRESS [NKK 01] [AUTO TAKE  
ON]  
#####
```

***Automation Company Details for 2020/400***

<b>Company</b>	<b>Protocols Used</b>	<b>Baud Rates</b>
Crispin	Auto / Rev2	
Digital Broadcast	Auto	Default 4800
Harris	Auto / Extend	
Florical	Auto / Extend	
Sundance	Auto / Extend Sidon version is 2.01S9-08/29/08	Default 38400 RS-422
Nversion	Auto / Extend	Assignable



### **AUTOMATION COMPANY DETAILS for SC-4/SC-400/SCX-400**

SUNDANCE	RCP-1i 38400 8, N, 1 RS-422. Sundance side AVS
----------	--

### **DEBUG2020 UTILITY**

There is a section at the bottom of the MC2020 and MC400 config files called [degug\_control\_start] that can be set to run logging for several areas of need. However, we recommend that this not be done as a permanent application due to the fact that it will run many additional entries to the logs of which may be unused information. These can also be set permanently to flash from the diag port

The best way to run these items is to telnet to the MC2020 or the MC400 and type the following:

debug2020 (displays all of the possible operations used to turn on debug messages.)

debug2020 display (shows all of the group flag names as ON or OFF)

debug2020 set PANEL <enter name here> <enter ON or OFF here> (sets temp flag)

debug2020 set GENERAL <enter name here> <enter ON or OFF here> (sets temp flag)

debug2020 set TRANS <enter name here> <enter ON or OFF here> (sets temp flag)

debug2020 set MACHINE<enter name here> <enter ON or OFF here> (sets temp flag)

debug2020 set ROUTER <enter name here> <enter ON or OFF here> (sets temp flag)

debug2020 set SYSLOG <enter name here> <enter ON or OFF here> (sets temp flag)







# 6

## MC-2020/MC-400 Logo Generation/ Program Installation

This Appendix covers the program installation for the MC-2020 Logo Generation utility. This process presumes the general system installation (described earlier in this guide) has taken place. The MC-2020 Logo Generation will allow you to import previously created .PNG files and convert them to the file format used by the UTSCI operating system.

**Note: Though the MC-2020 is referenced in this appendix, the functionality is the same for MC-40/400 operation.**

This Appendix includes the following:

Installation of the Microsoft™ .net Framework .....	6-2
Installing the 2020 Logo Conversion Application .....	6-3
Creating a USI Format Logo File .....	6-3
Installing a Logo into a MC-2020 Master Control Channel .....	6-6
Displaying a logo you have installed into the MC-2020 .....	6-7
Clearing Existing Logos .....	6-9

## Installation of the Microsoft™ .net Framework

Locate the release-logogen directory, then open the net-1.1 directory and double-click the dotnetfx.exe application.

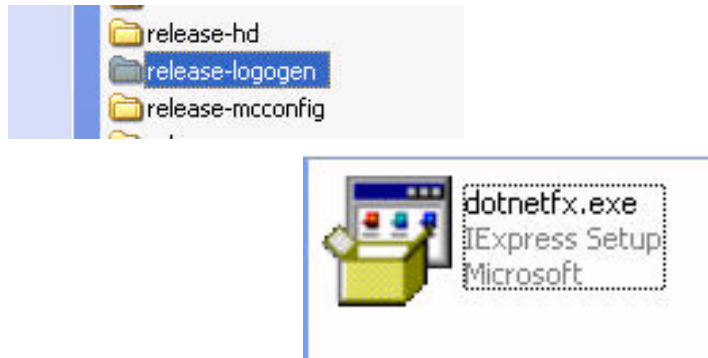

Depending on your equipment, this installation could take several minutes to complete. (Newer systems will allow the install to complete quickly.)



Next, launch the NDP1.1sp1-KB867460-x86.exe application by double-clicking the icon (same directory as above). This process is the Service Pack 1 installation, and will ask you to confirm and accept before continuing.<sup>1</sup>

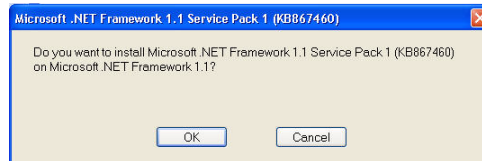

When the installation is complete, the following dialog will appear.

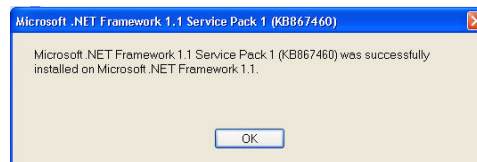

---

1. In a few isolated instances, some systems have reported the installation as “Already Complete”. This has not affected the proper installation however.



### Installing the 2020 Logo Conversion Application

Create a new sub-directory within your USI directory called 'logogen', then copy the MC2020LogoGen.exe application, along with all other files in the original folder, to this location.

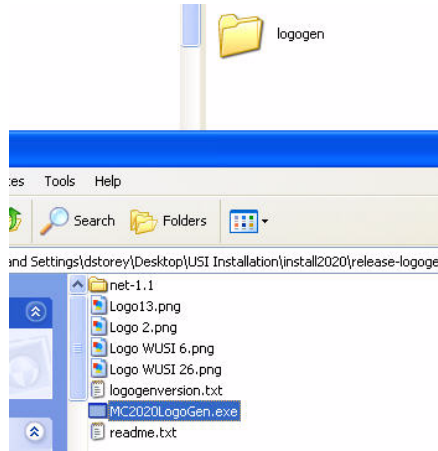

Once you have done this, make a short cut for this program to your desktop. Now copy any .PNG files you have created to the new logogen directory.

### Creating a USI Format Logo File



Launch the MC-2020 LogoGen utility.

Select the Video format using the format pick list. The default is SD525.

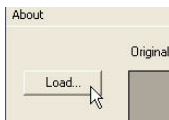

Click the **Load** button.

Now select the image you would like to read in.

**Note:** *This must be in the .PNG format.*

Use the height control to reduce the size of the logo (if desired). The width value will adjust automatically to keep the aspect ratio correct.

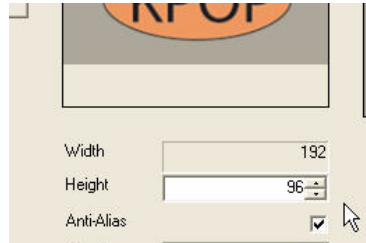

You must click the **Apply** button to see the resulting modification.

Use the vertical and horizontal adjustments to set the default location of the logo. *Note that in this case, you will not see immediate, on-the-fly changes.*

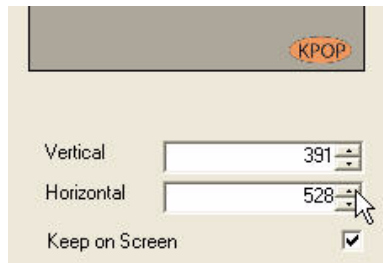

**Note:** *This location information is used by the MC-2020 when it loads the logo from memory into 1 of the 4 keyers. If necessary, the location can be further modified using the controls on the MCP-2020 series master control panel.*

Unless instructed otherwise, it is best to leave the 'Anti-Alias', 'Algorithm', and 'Keep on Screen' controls in their default setting.





Click the **Save** button.

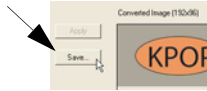

Provide a filename for the save. The extension will default to .lgo.



**Note:** *Do not change the extension name.*

This completes the conversion process.

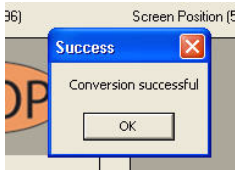

### **What is 'Background On' ?**

If the logo you are converting is semi-transparent or contains transparent edges, **Background On** (when checked) will allow you to see the effects of the transparency on a patterned background.

## Installing a Logo into a MC-2020 Master Control Channel

The MC-2020 is capable of storing a total of 16 different logos. Each logo occupies 1 of 16 storage locations inside the MC-2020. To place a logo into an MC-2020 system it must first be converted to the USI format (.lgo), then installed into the MC-2020 itself. The following steps will complete the installation of a logo in the first of the 16 location within the MC-2020. There is a working assumption here that the USI format file has already been created.

**Note:** *In the following discussion, 'system name' refers to the device as it was installed using the install2020.exe program. Examples include KUSI-SD01, KUSI-HD01, etc.*

1. Locate the converted logo file (filename.lgo).
2. Copy the converted logo file into c:\usi\[system name]\logos\[location.lgo]

**Note:** *The location can be from 1 to 16.*

### Example:

The 1.lgo file will be placed into the 1st of the 16 possible logo storage locations in the MC-2020 master control system.

The 2.lgo file would use the 2nd storage location.

3. Open Windows Explorer.
4. Navigate to c:\usi\[system]-name]\logos
5. Double-click burn-logos.bat and follow the on-screen prompts. This process updates the MC-2020 with up to 16 new logo files that are present in the c:\usi\[system-name]\logos directory.

**Note:** *Files not present in the logos directory are not changed in the MC-2020.*

The process is now complete.



## Displaying a logo you have installed into the MC-2020

At the MCP-2020 Master Control Panel, select the HOME button -- immediately below and to the left of the main LCD display.

Select the KEY button on the LCD touchscreen. This displays the key summary screen.

Select the KEY-1 button on the LCD touchscreen. This displays the logo select screen.

Select the LOGO-1 button on the LCD touchscreen. Any of the buttons can be selected if they have been loaded with a #.lgo file.

Turn on the PST KEY button for keyer 1 in the key section on the right hand side of the MCP-2020 control panel.

Select the LOGO key input button, located to the right of the EXT button and directly below the PST KEY button for the keyer 3.

**Note:** *The Logo button must be enabled in the MCP-2020 encoding file.*

Adjust the logo position using the bottom 2 knobs located directly to the right of the LCD display screen.

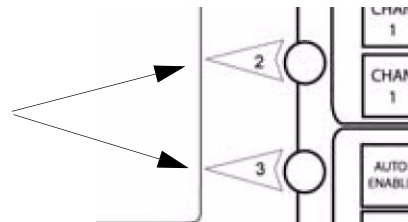

The middle knob adjusts horizontal position, the bottom knob adjusts vertical position.

The logo position can only be changed with the logo select screen displayed. When you are satisfied with the location, press the BACK button, located just below and to the right of the LCD display. If you need to make adjustments at a future time, go to the logo key select screen in the LCD and adjust with the knobs as necessary.

Each Logo is independently positioned. If you have a need for the same logo to be placed in 1 or more predefined positions, install the same logo in 1 or more **keyer card** slots and position each per your adjustments. A specific logo can actually be loaded in all the remaining keyer cards in your system.

***All internal logos should be displayed in the LIN MULT (or LIN) Keyer Mode.***





## Clearing Existing Logos

This must be completed from the diagnostics port either using a serial connection to the card or by telnetting into the IP address of the card. (Refer to Appendix D in the system installation guide). This will erase all logos at one time, and not individually. After all are removed, resend wanted logos back to the card.

Type the following at the prompt once you have established a connection:

**mem** (lower case and then press return)

r 6e0000 (these are zeros -- pressing return displays the current logos) ef  
6e0000 (these are zeros -- pressing return erases all logos in flash).

The following is an example of what is displayed after these commands are typed. You should see the actual name of the logos in each location at the end of the line in table one (below).

This was extracted from a 2020, and as you can see, there are two logos enabled. The second table shows the table with all ffff, indicating the address showing logos is empty.

/> mem

```
*****
*      Utah Scientific      *
*      Hardware Test Utility  *
*                          *
* Use "?" for help          *
* Motorola M5307C3 boot Version: V1.1 *
*****
>>r 6e0000
006e0000: face0001 000000ff 00010800 20050412
006e0010: 00000164 0000026d 00000000 deaddead      d m
006e0020: 00000100 00000001 00000000 deaddead
006e0030: deaddead deaddead deaddead deaddead
006e0040: 77757369 362e6c67 6f000000 00000000      wusi6.lgo
006e0050: 00000000 00000000 00000000 00000000
006e0060: 00000000 00000000 00000000 00000000
006e0070: 00000000 00000000 00000000 00000000
006e0080: 4c6f676f 20362057 55534920 636f7079      Logo 6
WUSI copy
006e0090: 2e706e67 00000000 00000000 00000000      .png
006e00a0: 00000000 00000000 00000000 00000000
006e00b0: 00000000 00000000 00000000 00000000
006e00c0: deaddead deaddead deaddead deaddead
006e00d0: deaddead deaddead deaddead deaddead
006e00e0: deaddead deaddead deaddead deaddead
006e00f0: deaddead deaddead deaddead deaddead
>>
```



```
>>ef 6e0000
Man id: 1, dev id: 22d7
>>r 6e0000
006e0000: ffffffff ffffffff ffffffff ffffffff
006e0010: ffffffff ffffffff ffffffff ffffffff
006e0020: ffffffff ffffffff ffffffff ffffffff
006e0030: ffffffff ffffffff ffffffff ffffffff
006e0040: ffffffff ffffffff ffffffff ffffffff
006e0050: ffffffff ffffffff ffffffff ffffffff
006e0060: ffffffff ffffffff ffffffff ffffffff
006e0070: ffffffff ffffffff ffffffff ffffffff
006e0080: ffffffff ffffffff ffffffff ffffffff
006e0090: ffffffff ffffffff ffffffff ffffffff
006e00a0: ffffffff ffffffff ffffffff ffffffff
006e00b0: ffffffff ffffffff ffffffff ffffffff
006e00c0: ffffffff ffffffff ffffffff ffffffff
006e00d0: ffffffff ffffffff ffffffff ffffffff
006e00e0: ffffffff ffffffff ffffffff ffffffff
006e00f0: ffffffff ffffffff ffffffff ffffffff
>>
```





# A

## Software and Program Removal

### Overview

In the event Utah Scientific software or utilities have previously been installed on your PC, certain utilities (on your Install CD) may not completely load -- as the program assumes the software is already in place. For the best results, new installations of the Utah Scientific software package require removal of all previous UTSCI program versions and directories.

If you are already familiar with Windows™ directory and program removal, you can simply review the listing on the next page for the items to be deleted.

Steps 1 through 3 describe the complete process involved in removing outdated versions from your computer, and preparing the system for a clean install.

**Notes:** *If a USI Software Installation prior to version 3.0 exists on your system, copy all USI folders to a new directory called 'usi\_old'. This will keep certain key files intact in the event any are needed for future back-ups.*

: *Though there won't be a large variation in the visual aspects of different Windows™ operating systems, this instruction is geared toward the use of Windows XP™.*

## Objective

This appendix will describe the removal process for the following UTSCI-related directories and utilities:

### *Directories*

- USI
- rMan V2
- U-CON V4

### *Utilities*

- ProNFS
- Tera Term Pro

## Step One - Program Removal

Start by using your Windows™ control panel to remove previous versions of the installed utilities. From the **Start** menu, click *Control Panels*.

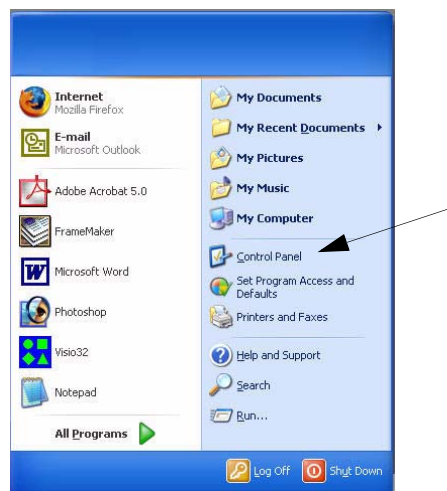

When the next window appears, select **Add-Remove Programs**.

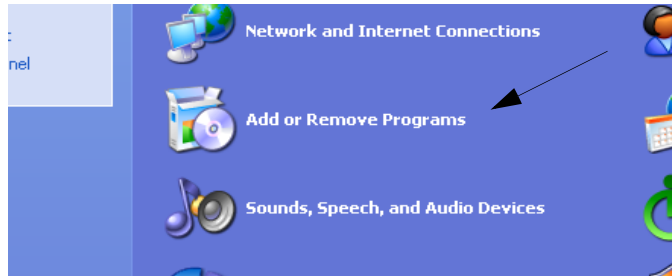

Once the program list is populated, locate both *ProNFS* and *Tera Term Pro*.

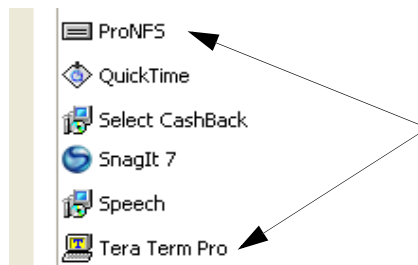

Highlight each program, then one at a time, select both for system removal.

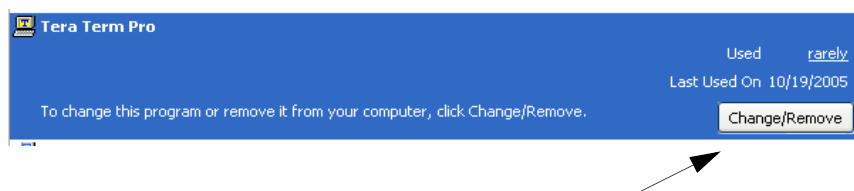

The removal of both programs will proceed with dialogs asking you to confirm the actual deletion. However when deleting Tera Term, the system will ask whether or not you would like to include all files in the removal. Click the checkbox, then continue (OK).

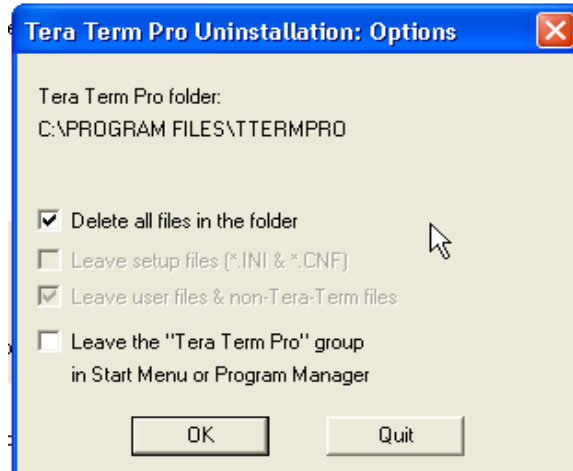





## Step Two - Directory Removal

**Note:** As mentioned earlier, it is best to save USI software (prior to version 3.0) in a newly created directory called **usi\_old**. Newer software sets can be removed.

The removal of UTSCI-related directories from your system is very simple. The remaining program utilities (U-CON V4 and rMan V2) are located inside the USI directory on your 'C' drive. From the Windows™ Explorer, locate this folder (directory) and drag it to your recycle bin.

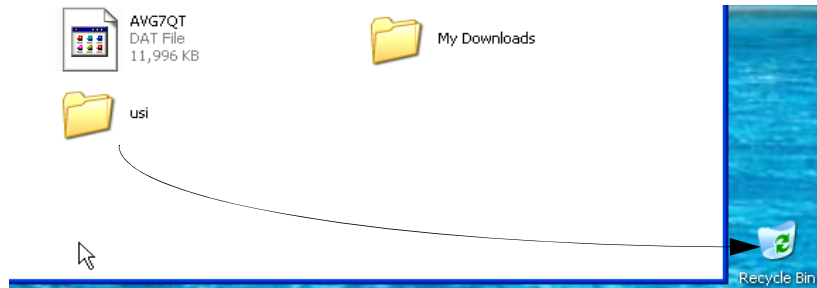

Or simply right-click the folder and select 'Delete' from the pop-up menu.

It is also necessary to remove the **Labtam** directory from your *Programs* directory.

In the same manner as above, open your Programs folder (directory) and either right-click to delete the folder, or just drag it to the Recycle bin.

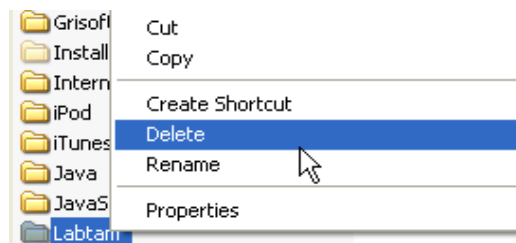

### Step Three - Java™ Removal (Optional)

In order to run properly, the rMan V2 utility places its own version of Java™ on your system. It is likely you already have another version of Java™ in place for other utilities.

To proceed with a clean re-installation (Section One), remove the version of Java™ that was loaded during rMan V2 installation.

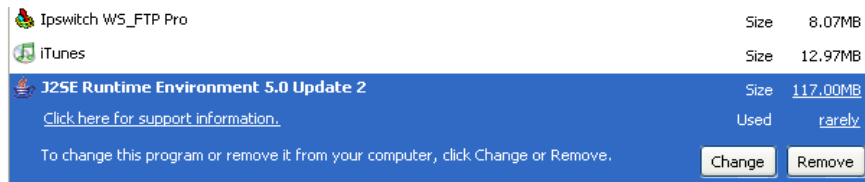

Again, you can remove rMan V2's version of Java™ for a clean re-installation -- particularly useful when newer versions are available. However, older versions are not likely to disrupt your rMan V2 operation.

This concludes the UTSCI Program and Utility Removal procedure.



# B

## Batchfile Description Table

### Introduction

New folders will be created (within the 'USI' directory) for each installed device -- see *Section 1, 'Install 2020 Installation'*. The folder name becomes that which was chosen during this procedure, followed by the device and the number '01'. If multiple devices "of the same type" were installed, the only difference in the folder names would be the number at the end. Example; 02, 03, etc.

There are multiple functions found in these folders, such as retrieving and sending configuration files, retrieving system information (software and firmware versions), and upgrading the software and firmware within these devices. Each of these functions has been set up to use specific batch files. The following tables are examples of the batch files found in the SC-4 folder. All other devices will follow this same table format. The description at the top of each table is the folder name found in c:\usi.

## C:USI Batch File Definitions

The following definitions are for all of the script files that run from the c:\usi directory. NFS Server must be running in order for these files to operate. Each heading noted below represents the folder in this directory where these files reside. They can be run directly from these locations or by use of the UTSCI Installation Utility. (See the Systems Installation Guide chapter 5 for directions on how to use this utility)

### SC4/SC400/SCVX400

#### ***Encode Folder***

*Note: xxxx represents call letters preceding device type. All batch files work the same for each of these devices. Descriptions are alphabetical.*

SC-4 location – c:\usi\xxxx-sc401\encode

SC-400 location – c:\usi\xxxx-sc401\encode

SCVX-400 location – c:\usi\xxxx-sc401\encode

burnenc-network.bat – sends the config file to the device and resets device

burnenc-network-nr.bat – sends the config file to the device with no reset

encodingedit.bat – opens the config file using WordPad editor

encodingsave.bat – saves the config file to the desktop

getencode.bat – retrieves the config file from the device and places it in the encode folder

setpids.bat – sets names into control panels from text file in same directory



### **Updates Folder**

Note 1: xxxx represents call letters preceding device type. All batch files work the same for each of these devices. Descriptions are alphabetical.

Note 2: Although the batch file called rel\_r1-9-1.bat performs upgrades to both the software and firmware of this device it is possible to only perform the upgrade to either the software or the firmware. This is done by going into the folders listed in the definition for the rel\_r1-9-1.bat below and running the batch file called burnsw-network.bat for the software and burnfw-network.bat for the firmware.

SC4 location – c:\usi\xxxx-sc401\updates

SC400 location – c:\usi\xxxx-sc401\updates

SCVX-400 location – c:\usi\xxxx-sc401\updates

chassisops.bat – allows changes to chassis ID, cust name and IP addresses

getrevision.bat – displays software version and Mac addresses

getsysinfo.bat – retrieves versions and config file and saves in this folder

getversion.bat – displays the current device software version

ipburn-serial – changes device IP - must use serial cable and change IP add in the file called devip\_add.dat in the xxxx-sc401 folder to new number

lockclear.bat – clears all system locks and protects stored in the SC4

lockdisplay.bat – displays details of all system destination locks and protects

netverify.bat – verifies IP adds, NFS Server and correct folder location

nfsmount.bat – mounts the SC4 ram drive to the NFS Server

nmsverify.bat – checks for duplicate device names

rel\_r1-9-1.bat – runs upgrade files from the sc4sw\_r1-9-1 and sc4fw\_r02-21 software and firmware folders

rel\_tmplt.bat – unused

rtrload.bat – loads the refresh table file produced from rtrsave.bat file

rtrsave.bat – saves the refresh table to file saved in \updates\router folder

setipaddresses.bat – sets and saves pc and device IP address for batch files

sysinfosave.bat – must run getsysinfo.bat first – this saves the file to desktop

telnet.bat – makes telnet connection to SC4

## Batchfile Description Table

---

tielineclear.bat – clears tie line status but leaves tie line connected

tielinedisplay.bat – displays current tie line table and connection status

SD/HD-2020/MC-40/400 CHANNELS

### ***Encode Folder***

Note: xxxx represents call letters preceding device type. All batch files work the same for each of these devices. Descriptions are alphabetical.

SD-2020 location – c:\usi\xxxx-sd01\encode

HD-2020 location – c:\usi\xxxx-hd01\encode

MC-40 location – c:\usi\xxxx-mc4001\encode

MC-400 location – c:\usi\xxxx-mc40001\encode

burnenc-network.bat – sends the config file to the device and resets device (MC40 and MC400 sends to both the panel and the card)

burnenc-network-nr.bat – sends the config file to the device with no reset

burnextra-network.bat – sends the extra config file to device and resets (2020 only)

burnextra-network-nr.bat – sends the extra config file to device with no reset (2020 only)

encodingedit.bat – opens the config file using WordPad editor

encodingsave.bat – saves the config file to the desktop

getencode.bat – retrieves the config file from the device and places it in the encode folder

### ***Updates Folder***

Note 1: xxxx represents call letters preceding device type. All batch files work the same for each of these devices. Descriptions are alphabetical.

Note 2: although the batch file called rel\_r3-00.bat performs upgrades to both the software and firmware of this device it is possible to only perform the upgrade to either the software or the firmware. This is done by going into the folders listed in the definition for the rel\_r3-00.bat below and running the batch file called burnsw-network.bat for the software and burnfw-network.bat for the firmware.



SD-2020 location – c:\usi\xxxx-sd01\updates  
HD-2020 location – c:\usi\xxxx-hd01\updates  
MC-40 location – c:\usi\xxxx-mc4001\updates  
MC-400 location – c:\usi\xxxx-mc40001\updates  
chassisops.bat – allows changes to chassis ID, cust name and IP addresses  
getrevision.bat – displays software version and Mac addresses  
getsysinfo.bat – retrieves versions and config file and saves in this folder  
getversion.bat – displays the current device software version  
ipburn-serial – changes device IP - must use serial cable and change IP add  
in the file called devip\_add.dat in the xxxx-sd/hd/mc40/mc40001 folder to new  
number  
netverify.bat – verifies IP adds, NFS Server and correct folder location  
nfsmount.bat – mounts the SC4 ram drive to the NFS Server  
nmsverify.bat – checks for duplicate device names  
rel\_r3-00.bat - runs upgrade files from the sds\_w\_r3-00 and  
sdfw\_r3-1-ee\_sd525 software and firmware folders (replace sd with hd and it  
is the same) – for the MC40 this runs the upgrade files from the  
mc40sw\_r3-00 and mc40fw\_2008-05-21\_1-5 folders (replace the mc40 with  
mc400 and it is the same)  
rel\_tmplt.bat – unused  
setipaddresses.bat – sets and saves pc and device IP address for batch files  
sysinfosave.bat – must run getsysinfo.bat first – this saves the file to desktop  
telnet.bat – makes telnet connection to Master Control device

## MCP-2020/MCP-40/MCP-400 Panels

### ***Encode Folder***

Note: xxxx represents call letters preceding device type. All batch files work the same for each of these devices. Descriptions are alphabetical.

MCP-2020 location – c:\usi\xxxx-mcp01\encode

MCP-40 location – c:\usi\xxxx-mcp4001\encode

MCP-400 location – c:\usi\xxxx-mcp40001\encode

burnenc-network.bat – sends the config file to the device and resets device

burnenc-network-nr.bat – sends the config file to the device with no reset

burnextra-network.bat – sends the extra config file to device and resets

burnextra-network-nr.bat – sends the extra config file to device with no reset

encodingedit.bat – opens the config file using WordPad editor

encodingsave.bat – saves the config file to the desktop

getencode.bat – retrieves the config file from the device and places it in the encode folder

### ***Updates Folder***

*Note 1: xxxx represents call letters preceding device type. All batch files work the same for each of these devices. Descriptions are alphabetical.*

*Note 2: Although the batch file called rel\_r3-00.bat performs upgrades to both the software and firmware of this device it is possible to only perform the upgrade to either the software or the firmware. This is done by going into the folders listed in the definition for the rel\_r3-00.bat below and running the batch file called burnsw-network.bat for the software and burnfw-network.bat for the firmware.*

MCP-2020 location – c:\usi\xxxx-mcp01\updates

MCP-40 location – c:\usi\xxxx-mcp4001\updates

MCP-400 location – c:\usi\xxxx-mcp40001\updates





chassisops.bat – allows changes to chassis ID, cust name and IP addresses  
getrevision.bat – displays software version and Mac addresses  
getsysinfo.bat – retrieves versions and config file and saves in this folder  
getversion.bat – displays the current device software version  
ipburn-serial – changes device IP - must use serial cable and change IP add  
in the file called devip\_add.dat in the xxxx-mcxxx01 folder to new number  
netverify.bat – verifies IP adds, NFS Server and correct folder location  
nfsmount.bat – mounts the SC4 ram drive to the NFS Server  
nmsverify.bat – checks for duplicate device names  
rel\_r3-00.bat - runs upgrade files from the mcpsw\_r3-00 and mcpfw\_r3-09  
software and firmware folders – for MCP-40 it runs upgrade files from the  
mcp40sw\_r3-00, mcp40fw\_v2.01 and mcp40sw-front-panel\_1.55 – for the  
MCP-400 it runs upgrade files from the mcp40sw\_r3-00, mcp40fw\_v2.01 and  
mcp40sw-front-panel\_1.54  
rel\_tmplt.bat – unused  
setipaddresses.bat – sets and saves pc and device IP address for batch files  
sysinfosave.bat – must run getsysinfo.bat first – this saves the file to desktop  
telnet.bat – makes telnet connection to Master Control Panel device

## ESI-2020

### ***Encode Folder***

*Note: xxxx represents call letters preceding device type. All batch files work the same for each of these devices. Descriptions are alphabetical.*

ESI-2020 location – c:\usi\xxxx-esi01\encode

burnenc-network.bat – sends the config file to the device and resets device  
burnenc-network-nr.bat – sends the config file to the device with no reset  
burnextra-network.bat – sends the extra config file to device and resets  
burnextra-network-nr.bat – sends the extra config file to device with no reset  
encodingedit.bat – opens the config file using WordPad editor

## Batchfile Description Table

---

encodingsave.bat – saves the config file to the desktop

getencode.bat – retrieves the config file from the device and places it in the encode folder

### ***Updates Folder***

Note 1: xxxx represents call letters preceding device type. All batch files work the same for each of these devices. Descriptions are alphabetical.

Note 2: Although the batch file called rel\_r3-00.bat performs upgrades to both the software and firmware of this device it is possible to only perform the upgrade to either the software or the firmware. This is done by going into the folders listed in the definition for the rel\_r3-00.bat below and running the batch file called burnsw-network.bat for the software and burnfw-network.bat for the firmware.

ESI-2020 location – c:\usi\xxxx-esi01\updates

chassisops.bat – allows changes to chassis ID, cust name and IP addresses

getrevision.bat – displays software version and Mac addresses

getsysinfo.bat – retrieves versions and config file and saves in this folder

getversion.bat – displays the current device software version

ipburn-serial – changes device IP - must use serial cable and change IP add in the file called devip\_add.dat in the xxxx-esi01 folder to new number

netverify.bat – verifies IP adds, NFS Server and correct folder location

nfsmount.bat – mounts the SC4 ram drive to the NFS Server

nmsverify.bat – checks for duplicate device names

rel\_r3-00.bat - runs upgrade files from the esisw\_r01-02 and esifw\_r03-06 software and firmware folders

rel\_tmplt.bat – unused

setipaddresses.bat – sets and saves pc and device IP address for batch files

sysinfosave.bat – must run getsysinfo.bat first – this saves the file to desktop

telnet.bat – makes telnet connection to ESI device



## MXLator

### ***Encode Folder***

Note: xxxx represents call letters preceding device type. All batch files work the same for each of these devices. Descriptions are alphabetical.

MXLator location – c:\usi\xxxx-mxlator01\encode

burnenc-network.bat – sends the config file to the device and resets device

burnenc-network-nr.bat – sends the config file to the device with no reset

burnsniffer-network.bat – burns code to capture logging of takes to a file

encodingedit.bat – opens the config file using WordPad editor

encodingsave.bat – saves the config file to the desktop

getencode.bat – retrieves the config file from the device and places it in the encode folder

### ***Updates Folder***

Note 1: xxxx represents call letters preceding device type. All batch files work the same for each of these devices. Descriptions are alphabetical.

Note 2: Although the batch file called rel\_r1-15.bat performs upgrades to both the software and firmware of this device it is possible to only perform the upgrade to either the software or the firmware. This is done by going into the folders listed in the definition for the rel\_r1-15.bat below and running the batch file called burnsw-network.bat for the software and burnfw-network.bat for the firmware.

MXLator location – c:\usi\xxxx-mxlator01\updates

chassisops.bat – allows changes to chassis ID, cust name and IP addresses

getrevision.bat – displays software version and Mac addresses

getsysinfo.bat – retrieves versions and config file and saves in this folder

getversion.bat – displays the current device software version

ipburn-serial – changes device IP - must use serial cable and change IP add in the file called devip\_add.dat in the xxxx-mxlator01 folder to new number

netverify.bat – verifies IP adds, NFS Server and correct folder location

## Batchfile Description Table

---

nfsmount.bat – mounts the SC4 ram drive to the NFS Server

nmsverify.bat – checks for duplicate device names

rel\_r1-15.bat - runs upgrade files from the mxlatorsw\_r1-15 and mxlator  
fw\_r02-06 software and firmware folders

rel\_tmplt.bat – unused

setipaddresses.bat – sets and saves pc and device IP address for batch  
files

sysinfosave.bat – must run getsysinfo.bat first – this saves the file to  
desktop

telnet.bat – makes telnet connection to MXLator device



# C

## Setting Panel ID's (Using the SC-4 Test Utility)

### Introduction

Each UCP panel on an SC4 system with U-CON V4 must have a unique panel ID. These ID's are set when the panel leaves the factory, but certain field operations can cause the panels to lose this ID. This document details how to set the panel ID so that it is usable with U-CON V4.

The common symptom of a panel in which the ID has been erased is a panel that when connected to the SC4, appears to work and recognizes it's connection to the SC4, but will not show up in the 'Active Devices' list in U-CON V4

### Required Equipment

- Either a telnet connection or a debug port connection from a PC to the SC4. **Use Tera Term or Hyper Term to connect to either port.**
- The dipswitch settings of the panels you wish to change

### Procedure

- Connect to the SC4.
- At the '/>' prompt, type in the word 'test' followed by return. A menu will be displayed that shows the commands available in this 'test' program. This document describes the 'getpid' and 'setpid' commands. The following will be displayed.

## SC-4 Test Utility Commands

Table C-1.

Command	Function
ping	ping SC-4 app
config <fstype> <path> <filename>	configure system
getcon <fstype> <path> <filename>	get configuration
shutdown	shutdown SC-4 app
startup	start SC-4 app
setpid <node> <name> <model>	set panel ID string
setplpid <node> <name> <model>	set PL panel ID string
getpid <node>	get panel ID string
getplpid <node>	get PL panel ID string
help	show command options
exit	exit program
quit	quit program

Type 'getpid' followed by the panel number you wish to query, followed by return. Example – "getpid 27". This command will display what the panels ID is currently set to. It may be helpful to do a 'getpid' to a panel that you know is functioning correctly with U-CON V4 to see what the format looks like. A typical correct response will be:

**"test> Panel 71 ID: DEMOROOM-XY UCP-XY "**

This response shows panel number 71 is set to ID "DEMOROOM-XY" and that its type is "UCP-XY". The panel type is very critical, as if it does not match a predetermined panel type, U-CON V4 will not know its layout, and will not be able to program it.



The list of allowable panel types is as follows:

1. SCP-XY/16
2. SCP-SX/16 – Used for SCP and UCP SX panels
3. SCP-MX/16 – Used for SCP and UCP MX panels
4. SCP-2 – Used for SCP and UCP -2 panels
5. SCP-32
6. SCP-64/8
7. UCP-XY
8. UCP-36
9. UCP-48
10. UCP-64
11. UCP-72
12. UCP-128
13. SCP-SD16

**Note:** The above are all case sensitive.

To set the panel id, use the 'setpid' command in this format:

1. setpid <node number> <ID – user definable> <panel type>. An example of this is – setpid 71 DEMOROOM1-XY UCP-XY.
2. The name and panel type cannot have any spaces but can have hyphens and underscores. The panel type must be typed exactly like seen above.
3. It is prudent to do a 'getpid' of this panel after you set it to make sure the information was updated correctly.

After you have set and verified the ID in the panel, two more steps need to be taken to have the panel recognized in U-CON V4.

1. Exit the test program. Type 'exit', or 'quit' followed by return to leave the test program.

## Setting Panel ID's (Using the SC-4 Test Utility)

---

2. The panel must be reacquired by the SC4 for the new ID to take effect. The easiest way to do this is to remove power from the panel for a period of 1 minute, and then re-apply power.
3. At this point, the panel should show up in the 'Active Devices' window in U-CON V4.

The following is an example session taken from an SC4 test shell.

```
Sash command shell (version 1.1.1)
```

```
/>
```

```
/> test
```

```
test>getpid 71
```

```
Panel 71 ID: DEMOROOM-XY UCP-XY
```

```
test>setpid 71 NEWNAME-XY UCP-XY
```

```
test> getpid 71
```

```
Panel 71 ID: NEWNAME-XY UCP-XY
```

```
test/>exit (or quit)
```

```
/>
```

If you have already created any panel's offline using the "Add New Device" section in U-CON V4 then you would have already created a name for that panel. This panel will have a red box around it until the created name matches the assigned name given the panel through the SC4 test utility. In this case, use the same steps above making sure to type the name in the setpid section exactly as it was created in U-CON V4. After it has been named, simply cycle the power and when the network finds the panel, the red box will go away.





For all CSP style of control panels (coax party line cable) you will use the same format as above for naming panels only the commands are getplpid and setplpid. The list for allowable panel types are:

- CP-4
- CSP-1600
- CSP-1602
- CSP-1605
- CSP-1610
- CSP-16160
- CSP-1910
- CSP-30
- CSP-40
- CSPD

In the event that you are unable to name a panel using this procedure, or if you have named it and the panel is still not recognized by U-CON V4, showing up in the Active Device List, then call Utah Scientific customer service for help.





# D

## Diagnostic Port Quick Commands

The following tables contain diagnostic port commands for the SC-4, SC-400, MCP-2020, SD/HD-2020, ESI-2020, and MX-Lator. These command sets are primarily used for;

- Displaying the Configuration file information
- Checking board numbers and versions (scangate information)
- Obtaining Debug information

and

- Displaying current device settings (serial port settings)

**Note:** See Page D-9 for proper connection to each device's terminal port. If the IP address (of the device) is known, you can access the terminal port using a telnet connection. Open Tera Term, establish a new connection, and copy a TCP/IP selection (as opposed to a serial selection).

## Terminal Commands for the SC-4 and Master Control

\*\*\*CASE SENSITIVE\*\*\*

### SC4/SC400 Commands

NOTE: For systems with 2 SC400 cards installed you will need to send the IP address and chassis ID to each card individually as these are stored on the card. These entries are stored in the chassis on SC4 systems.

### Chassis Functions

chassis (displays all of the chassis operations)

chassis -r (reads chassis info including IP addresses, customer name and chassis ID)

chassis -d (displays scangate version and card serial number)

chassis -init (removes chassis flash data - confirm using -r cmd. Must put IP, chassis ID, cust name back using commands below)

chassis - ip1 xxx.xxx.xxx.xxx (sets ip address for port 1)

chassis - ip2 xxx.xxx.xxx.xxx (sets ip address for port 2)

chassis - gw1 xxx.xxx.xxx.xxx (sets gateway address for port 1)

chassis - gw2 xxx.xxx.xxx.xxx (sets gateway address for port 2)

chassis - mask1 xxx.xxx.xxx.xxx (sets subnet mask for port 1)

chassis - mask2 xxx.xxx.xxx.xxx (sets subnet mask for port 2)

chassis -cust xxxx (sets the customer name in chassis; 1 to 24 entries allowed)

chassis -chid xxxx (sets the chassis ID used by U-CON V4; 1 to 24 entries allowed)

chassis -unet xx (unused)



## SC-4 Functions

- sc4config (displays all of the current operations used by sc4config)
- sc4config display (reads the configuration file from the SC400)
- sc4config routers (displays the physical router table)
- sc4config levels (displays the virtual router table)
- sc4config srcs 25 (displays the first 25 lines in the source table. Replace the 25 with however many you would like to display)
- sc4config dsts 25 (displays the first 25 lines in the destination table. Replace the 25 with however many you would like to display)
- sc4config mx (displays the size of the mx table)
- sc4config pl (displays the size of the party line table)
- sc4config serial (displays the serial port table)
- sc4config tieparms (displays tie line properties; max ties and max search table)
- sc4config pools (displays tie pools created in SC4 config)
- sc4config ties (displays tie line tables)
- sc4config dstpools (displays destination index numbers and tie pools they are assigned to)
- sc4config salvo 2 (displays salvo 2 assigned srcs and dsts; replace 2 with desired salvo)
- sc4config syslog (displays syslog name used in SC4)
- sc4config groups (displays group name tables for 8 and 4 char)
- sc4config custstat (displays custom status table)
- sc4config sim (turns simulation on for all levels; to turn simulation on for any single level add a space and then the level # after sim)
- sc4config nosim (turns simulation off for all levels; to turn simulation off for any single level add a space and then the level # after nosim)
- sc4config dstatrs (displays attribute table; for data router and audio attributes)
- sc4config master (unused)
- sc4config psrscs (unused)

sc4config pdsts (unused)

sc4config misc (unused – displays current encrypted password)

### **Router Functions**

router (displays all of the router operations)

router save display (prints out current status of refresh table using index numbers)

router xy 1-10 (this will route inputs 1-10 to outputs 1-10; what ever number or range is entered it will switch the ins to the outs)

router src 3 (this will route source 3 to all outputs; change the 3 to desired number and this will route to all outputs)

router killstatus (blanks out the refresh table)

### **Miscellaneous Terminal Commands**

lockdump (displays all locks and protects on the system. 0 = protect 1=lock)

lockdump clear (clears all locks – if only one needs to be cleared go to the panel)

logdump (displays entire event log in SC4 since last reset)

logdump 25 (displays only last 25 lines of events – enter desired amount after logdump)

mem (enters the memory utility for reading address information)

b (enter this while in the mem utility to check bootloader software version)

rx (enter this while in the mem utility to check firmware version – upper right corner)

tiedump (displays the tie pools created and connection status of any tie lines in use)

tiedump clear (clears status tie lines when doing tiedump but leaves tie lines connected)

sinv (displays the two control cards, part number, revs, SN# and their MAC addresses)



## MC-2020/MC-400

When performing commands for the MC400 you need to be connected to the MCP-400 and not the card.

NOTE: There are some operations that will appear that are not listed below. We recommend that you do not attempt to utilize these functions as they are reserved for help from Utah Scientific.

### Chassis Functions and Commands

chassis (displays all of the chassis operations)

chassis -r (reads chassis info including Ip addresses, customer name and chassis ID)

chassis -d (displays scangate version and card serial number)

chassis -init (removes chassis flash data - confirm using -r cmd. Must put IP, chassis ID, cust name back using commands below)

chassis - ip1 xxx.xxx.xxx.xxx (sets ip address for port 1)

chassis - ip2 xxx.xxx.xxx.xxx (unused)

chassis - gw1 xxx.xxx.xxx.xxx (sets gateway address for port 1)

chassis - gw2 xxx.xxx.xxx.xxx (unused)

chassis - mask1 xxx.xxx.xxx.xxx (sets subnet mask for port 1)

chassis - mask2 xxx.xxx.xxx.xxx (unused)

chassis -cust xxxx (sets the customer name in chassis; 1 to 24 entries allowed)

chassis -chid xxxx (sets the chassis ID; 1 to 24 entries allowed)

chassis -unet xx (sets the MC2020 channel node number)

## MC-2020 and MC-400 Functions

For MC400 commands you need to log into the MCP400.

HDconfig (displays all possible operations with this command)

HDconfig display (reads the configuration file from the CPU – 2020 and MC400)

HDconfig status (displays serial port jumpers in 2020 only, SW version and system name in 2020 and MC400)

HDconfig timeset (sets time and date for on board real time clock - format is HDconfig timeset mm/dd/yyyy hh:mm:ss - enter <tc> after timeset to set time to timecode)

HDconfig setembed (sets default sources to embedded audio)

HDconfig setdiscreet (sets default sources to discreet audio)

HDconfig sysname <new name here> (sets new system name in CPU)

HDconfig debug (sets debug flags perMan V2ently in flash – see debug commands below)

HDconfig dimlevel <put number here> (sets audio dim to this number 0 to -45 range)

## Miscellaneous Terminal Commands

mem (enters the memory utility for reading address information)

b (enter this while in the mem utility to check bootloader software version)

HDfirmware rev (reads fw for all cards installed in 2020. Only CPU in MC400)

sinv (reads inventory of cards installed in the 2020 chassis. MAC add only in MC400)

debug2020 (displays all of the possible operations used to turn on debug messages.)

debug2020 display (shows all of the group flag names as ON or OFF)

debug2020 set PANEL <enter name here> <enter ON or OFF here> (sets temp flag)





debug2020 set GENERAL <enter name here> <enter ON or OFF here> (sets temp flag)

debug2020 set TRANS <enter name here> <enter ON or OFF here> (sets temp flag)

debug2020 set MACHINE<enter name here> <enter ON or OFF here> (sets temp flag)

debug2020 set ROUTER <enter name here> <enter ON or OFF here> (sets temp flag)

debug2020 set SYSLOG <enter name here> <enter ON or OFF here> (sets temp flag)

### **MCP-2020/MCP-400**

NOTE: There are some operations that will appear that are not listed below. We recommend that you do not attempt to utilize these functions, as they are reserved for help from Utah Scientific.

MCPconfig (displays all possible operations with this command)

MCPconfig display (reads the configuration file from the MC Panel)

MCPconfig status (displays software version and chassis connection table)

MCPconfig timeset (sets time and date for on board clock - format is HDconfig timeset mm/dd/yyyy hh:mm:ss - enter <tc> after timeset to set time to timecode)

### **Miscellaneous Terminal Commands**

MCPconfig display (reads the configuration file from the CPU – 2020 and MCP400)

mem (enters the memory utility for reading address information)

b (enter this while in the mem utility to check bootloader software version)

## Device Software Lookup

Complete the following steps to lookup, or verify the software version in the SC4, SC400, MXLator, MC2020, MCP2020 and ESI2020.

**Note:** If the device is already connected to the network (and Tera Term is running), you can bypass steps 1 - 9, select the TCP/IP connection, and proceed to step #10.

1. Connect the UTSCI Serial port to the RJ-45 adapter (Marked SC-4/2020 on your PC COM port).
2. Place a standard straight through CAT 5 cable from the PC adapter to the front RJ-45 port on the desired device.
3. Launch Tera Term Pro, open the Setup menu, select Serial Port and complete the following:
  4. Select the desired port (COM 1, 2, etc.)
  5. Set the Baud Rate to 19200.
  6. Set the Data to 8-bit.
  7. Set the Parity to None.
  8. Set the Stop to 1-bit.
  9. Set flow control to None.
10. Click OK.
11. At the prompt type **mem** (and press ENTER) The following screen will appear.

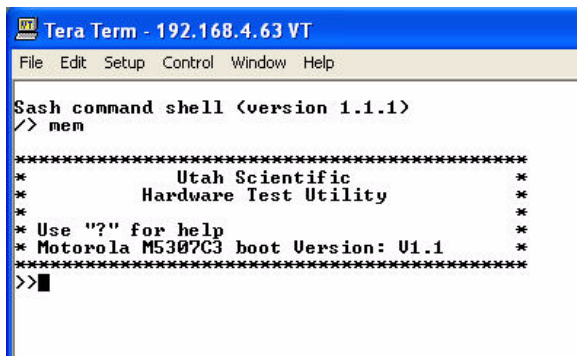

```
Tera Term - 192.168.4.63 VT
File Edit Setup Control Window Help
Sash command shell <version 1.1.1>
/> mem
*****
*           Utah Scientific           *
*       Hardware Test Utility       *
* Use "?" for help                  *
* Motorola M5307C3 boot Version: U1.1 *
*****
>>■
```



12. Next, type the letter b (lower case). ENTER

The following screen will appear.

```
Tera Term - 192.168.4.63 VT
File Edit Setup Control Window Help
-----
BootAddress      600000
CRC              = dabeda57
Version          = SC4_1-6-2#1_05/02/2007_19-01-45
Size             = 328500
BuildDate        = Wed May 2 19:01:45 2007
BurnDate         = Sat Mar 03 20:24:36 2001

-----
Partition 2 Information
-----
BootAddress      400000
CRC              = c985103d
Version          = SC4_1-4-1#3_03/20/2006_18-25-09
Size             = 36c0b8
BuildDate        = Mon Mar 20 18:25:11 2006
BurnDate         = Fri Jun 29 10:48:14 2007
>>
```

The version (pointed to above) is the device's current software version, for the indicated device - in this case an SC-4.

13. At the prompt type exit to leave the terminal mode.

## Locating the IP Address for Additional System Devices

Complete the following steps to locate IP addresses for devices such as the SC-4, MX-Lator, SC-400, or the MC-2020.

1. Connect the UTSCI Serial port to the RJ-45 adapter (marked SC-4/2020 on your PC COM port).
2. Place a standard straight through CAT 5 cable from the PC adapter to the front RJ-45 port on the desired device.
3. Launch **Tera Term Pro**, open the **Setup** menu, select *Serial Port* and complete the following:
4. Select the desired port (COM 1, 2, etc.)
5. Set the Baud Rate to **19200**.
6. Set the Data to **8-bit**.
7. Set the Parity to **None**.
8. Set the Stop to **1-bit**.
9. Set flow control to **None**.
10. Click **OK**.
11. In the prompt window, verify communication by pressing the space bar. If you are communicating properly you will see the */>* symbol and a blinking box.
12. Type (lower case) *ifconfig*, then press ENTER. Your system detail should begin to scroll on the PC Tera Term window.



## Changing IP Addresses in System Devices

The IP address for each device is actually located in that devices chassis. Note: this should be performed with care and done when there is adequate time to allow for the device to be reset. This may require bypassing some routes if the changes are done to the Master Control as there will be a few seconds of interrupted on air video and audio.

Complete the following steps to change the IP address in the SC4, SC400, MXLator, MC2020, MCP2020 and ESI2020.

**Note:** If the device is already connected to the network, you can bypass steps 1 - 9, select the TCP/IP connection, and proceed to step #10.

1. Connect the UTSCI Serial port to the RJ-45 adapter (Marked SC-4/2020 on your PC COM port).
2. Place a standard straight through CAT 5 cable from the PC adapter to the front RJ-45 port on the desired device.
3. Launch Tera Term Pro, open the Setup menu, select Serial Port and complete the following:
4. Select the desired port (COM 1, 2, etc.)
5. Set the Baud Rate to 19200.
6. Set the Data to 8-bit.
7. Set the Parity to None.
8. Set the Stop to 1-bit.
9. Set flow control to None.
10. Click OK.
11. At the prompt type chassis -r to view the current IP address for that device. (Insert bottom picture and notes from SIG page 2-12 here)
12. At the prompt type chassis -ip1 xxx.xxx.xxx.xxx (xxx's = new address) to change the IP address. Note: this will also change the subnet and router addresses automatically to correspond with the new IP address.

13. Reset that device in order for the changes to take effect. If this is to be done on the SC4, SC400 or MXLator you will need to take note of which card is currently the active card (locate the active green LED on the card) and then press and hold the reset button on both the active and back up cards, and then releasing the active cards reset button first followed by the back up card. This will ensure that the system comes back up on the active card. If this is not followed the changes will not take effect. The MC2020 and MCP2020 devices only have one card to reset. The MC2020 reset is located near the center of the CPU card on the inner side, not the top button. MCP2020 reset button is located right next to the RJ45 connector that the serial cable is attached to.
14. At the prompt type chassis -r and verify that the new address was accepted.

**Note:** **Note: The SC4 is the only device that has two IP address ports on the rear of the chassis. These are two NICs and if the second port is needed you will follow the procedures above replacing the command chassis -ip1 with chassis -1p2. These must be two separate subnets as they are literally two distinct network interface cards. The second port can be used for attaching Ethernet devices such as Utah Scientific Ethernet panels; however the U-CON V4 software must be connected via port 1.**



## Changing Gateway and Mask Addresses in SC-4/SC-400

1. Launch TeraTerm and connect to the SC4/SC400 (.).

**Note:** If the device is already connected to the network, you can bypass steps 2 - 10, select the TCP/IP connection, and proceed to step #11.

2. Connect the UTSCI Serial port to the RJ-45 adapter (Marked SC-4/2020 on your PC COM port).
3. Place a standard straight through CAT 5 cable from the PC adapter to the front RJ-45 port on the desired device.
4. Launch Tera Term Pro, open the Setup menu, select Serial Port and complete the following:
  5. Select the desired port (COM 1, 2, etc.)
  6. Set the Baud Rate to 19200.
  7. Set the Data to 8-bit.
  8. Set the Parity to None.
  9. Set the Stop to 1-bit.
  10. Set flow control to None.
  11. Click OK.
12. At the /> prompt type chassis -r to view the network connections.
13. To add or change the gateway type chassis -gw1 xxx.xxx.xxx.xxx (xxx's = new address).
14. To change the netmask type chassis -mask1 xxx.xxx.xxx.xxx (xxx's = new address).
15. Reset that device in order for the changes to take effect. If this is to be done on the SC4, SC400 or MXLator you will need to take note of which card is currently the active card (locate the active green LED on the card) and then press and hold the reset button on both the active and back up cards, and then releasing the active cards reset button first followed by the back up card. This will ensure that the system comes back up on the active card. If this is not followed the changes will not

## Diagnostic Port Quick Commands

---

take effect. The MC2020 and MCP2020 devices only have one card to reset. The MC2020 reset is located near the center of the CPU card on the inner side, not the top button. MCP2020 reset button is located right next to the RJ45 connector that the serial cable is attached to.



---

---

# E

## A Discussion About Timing

### Timing Sources into the MC-2020

It is very important that all sources that pass through the 2020 are in sync with the reference that comes into the reference port located in the lower right corner of the 2020 chassis.

The reference for the SD-2020 must be an SDI source that is constant such as SD black or color bars. The reference for the HD-2020 must be an HD source that is constant such as HD black or color bars. We recommend that this source comes from the generated house sync of which all sources are also in sync with.

The 2020 has a timing utility that is very useful. Its purpose is to compare the source that is currently in use on any of the three busses (PGM, PST, PVW) with the video reference and display the difference between the two in both vertical lines and horizontal pixels.

There are two ways to view this. One is serially using the diagnostics port located on the front of the 2020 CPU card or with a telnet connection using the CPU's IP address. The second way is via the LCD utility on the MCP-2020 control panel using the menu icon called Src Status located on the Maint button.

---

---

Note: The program will display the vertical and horizontal difference for all three busses when viewing it from the diagnostics or telnet ports and only the PGM and PST busses when viewing it using the MCP-2020 LCD utility menu.

## Using the Timing Utility

### 2020 Timing Utility DEFINITIONS:

Good Video [G] is a video source that complies with SMPTE standards for signal integrity (levels, jitter, clock rate all comply with SMPTE tolerances) from which the MC2020 Video receivers can reliably recover clock and data information.

Asynchronous Video [A] is a “good” video source with sync timing that drifts relative to the video reference input sync timing. This signal is NOT GenLocked. For this reason, the video source will drift in and out of the +/- 1 HLINE “Timed Video” window. Video Status will be erratic. Embedded Audio (for now) will be noise or sputtering sounds.

Un-timed Video [U] is a “good” video source that is GenLocked (not drifting) with sync timing that falls outside the +/- 1 HLINE “Timed Video” window relative to the video reference input sync timing. Video Status is stable. Embedded Audio (for now) may include noise or sputtering sounds.

Timed Video [T] is a “good” video source that is GenLocked (not drifting) with sync timing that falls within the +/- 1 HLINE “Timed Video” window relative to the video reference input sync timing. Video Status is stable. Audio is embedded without errors.

Usage and Display Format: (Defaults to slot 3 (VI), but can monitor Slots 4-7 (KM). Just state slot number after command. For Example, type: 2020timing 5 for slot 5.

Video Status Flags appear in order (GAUT). Lower case ‘x’ means not active.

PST does not give any status on KM Cards; PGM = KEY, PVW=FILL

Positive V & H #s mean the source is ahead of reference, Negative values mean behind.

Type CTL-C to exit the utility.

---

---

## Connecting Via Serial

1.Plug the serial adapter (pn# 140100-2 supplied by Utah Scientific) into the COM port of the config pc. If you are unable to locate this adapter it can be easily built using the following pin out.

RJ459pin

1 - 2

3 - 3

4 - 5

5 - 8

7 - 7

2.Attach a standard CAT5 cable (straight through) between the adapter and the RJ45 connector located on the front of the 2020 CPU card. (This card is installed in the far left slot of the 2020 chassis)

3.Run the TeraTerm terminal program (supplied by Utah Scientific on the system CD in the directory called PC Prep) or other desired program such as Hyper Term. In TeraTerm select serial and choose the pc COM port you are using. Set baud rate to 19200 and parity to 8N1 in the serial port settings.

4.Hit the return key and you should get a prompt that looks like this />. At the prompt type 2020timing (case sensitive) to start the program.

## Connecting Via Telnet

(To use telnet the 2020 CPU must be on the same subnet as the computer)

1.Run the TeraTerm terminal program (supplied by Utah Scientific on the system CD in the directory called PC Prep) or other desired program such as Hyper Term. If using another program, make sure it can work with TCP/IP sessions. In TeraTerm select TCP/IP and enter the IP address of the 2020 CPU card.

2.Hit the return key and you should get a prompt that looks like this />. At the prompt type 2020timing (case sensitive) to start the program.

## Using LCD on MCP-2020 Panel

**Note:** (Note: timing displayed using this method is not updated instantly. There is a delay)

- 
1. Push the Home button located just below the LCD.
  2. Push the Maint button located on the LCD.
  3. Push the Src Select button located on the LCD.
  4. This is the utility and will only display the source in use on the PGM and PST busses. The PVW section will not display here but only using the serial or telnet method.

## Adjusting Timing

(Recommended method is using serial or telnet as these will update in real time)

1. In most cases each source device from frame syncs to servers to DTR's will have some form of adjustments for the V (vertical) and H (horizontal) timing. You will need to refer to each device manual to find this procedure.
2. Push the source that you want to look at on any of the three busses (PGM, PST, PVW) and look at the terminal. You will see the V displayed in lines and the H displayed in pixels for that source.
3. Adjust the V and H for that device while watching the terminal. The closer you bring the V and H to zero the better the 2020 will operate. The spec is + or – one horizontal line which means that you must have the V at 000 but the H can be anywhere from 0000 to + or – 858 pixels for SD, + or – 2200 for 1080i HD and + or – 1650 for 720p HD.

## Timing for Systems Using SqueezeMAX

Although the spec for the sources coming into the 2020 is + or – one horizontal line and is very forgiving, the SqueezeMax is not and the timing must be very tight. This timing is still done using the procedure above and had to do with the sources coming into the 2020 and not the SqueezeMax.

Symptoms of untimed sources through the SQM may be broken up video, glitches or slight bumps in the video as well as loss of or distorted closed caption.

## SD SqueezeMAX Timing Upstream

In this application the SQM would connect into the 2020 through one of the keyers. Sources must be timed coming into the SD-2020 using the timing procedure and must be less than ½ of a horizontal line. This would mean that the V is 000 and the H is + or – 500 pixels. We recommend that the sources be adjusted to as close to zero as possible when using SQM.

---

---

## **SD SqueezeMAX Timing Downstream**

In this application the input of the SQM would connect to the PGM output of the 2020. It still requires a reference source of SD black or color bars and all sources must still be timed the same into the 2020 as in upstream mode using the following procedure. This would mean that the V is 000 and the H is + or – 500 pixels. We recommend that the sources be adjusted to as close to zero as possible when using SQM.

## **HD SqueezeMAX Downstream**

The HD SqueezeMax does not use an external reference. There are only two connections to be made. One is the video input and the other is the video output. It gets the reference from the video input. There is a delay of 7 frames through the HD SQM and for this reason it is recommended that it be used in the downstream mode only. In order to use it upstream the PGM bus input to the 2020 must also be delayed by 7 frames. We recommend that the sources be adjusted to as close to zero as possible when using SQM.

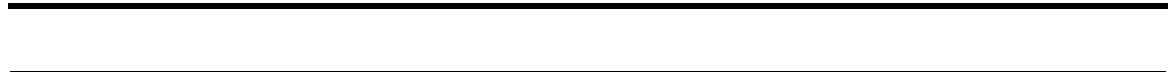

---

---

# F

## EAS Setup

### MC-2020 EAS Upgrade

(This is to be used for upgrading the MC-2020 and MCP-2020 to enable EAS functionality for serial interface and audio Macro play out)

1. Unzip your new CD 3.XX (must be 3.41 or newer) files to C:\USI
2. Go to section 2 of your System Installation Guide

#### Files Currently on the CD



located on this CD for the USI file upgrade procedure.

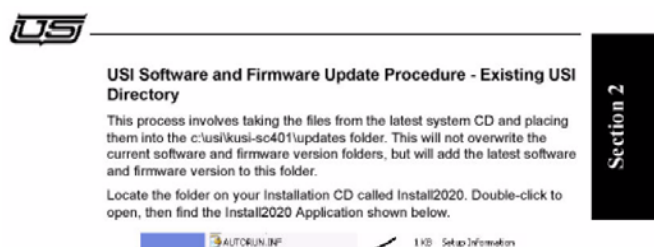

---

Once you have read through and followed the procedure leading to the Software and Firmware Update Procedure of section 2,

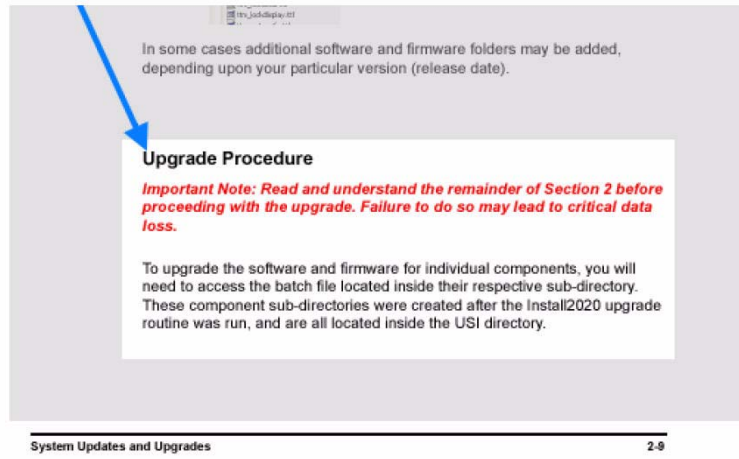

**follow these instructions to configure your system.**

Configuring System using MCConfig Application (for TFT, Sage and Dasdec TFT)

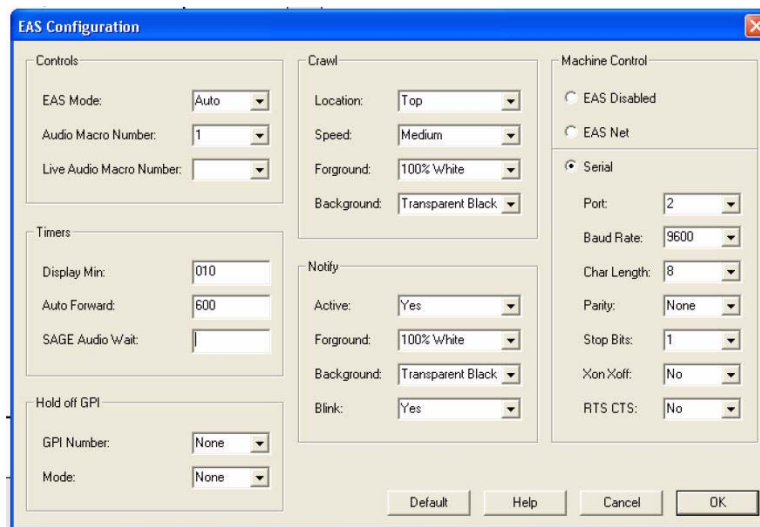

Click on 'EAS' in the top menu selection in MCConfig. Set all settings like these for TFT, Sage and Dasdec TFT.



---

EAS CONFIGURATION (set the following)

1. EAS MODE selects the mode for EAS operations. AUTO means we automatically forward an EAS Alert - MANUAL means we wait for operator command before we process - OFF means we ignore all inbound EAS commands/actions from the EAS device. Drop down menu and select mode.
2. Audio Macro Number selects the macro number for the audio to run when the EAS comes down. Default setting is 1. Drop down menu to choose correct one.
3. Live Audio Macro Number is used for National Alerts and unless your system runs this it is left at none.
4. DISPLAY MIN sets the minimum time an alert is displayed. Value is in seconds - Valid range is: 10 to 900. Usually a 10. Enter desired value in box.
5. AUTO FORWARD sets the max amount of time that will expire before the MC forces the EAS alert to be played. Valid range is: 10 to 900. Usually set to 600. Enter desired value in box.
6. SAGE AUDIO WAIT sets the max amount of time that will expire before the MC forces the EAS alert to be played. Valid range is: 5 to 900. Enter desired value in the box. This is generally unused and defaults to none.
7. GPI NUMBER is set to the MISC RELAY FUNCTION number encoded to control the relay attached to the HOLDOFF Function of the EAS device. Drop down menu and select relay number. This is generally unused and defaults to none.
8. GPI MODE Selects the type of HOLDOFF action used for the EAS device. The options are @, @NONE, @ACTIVE\_CLOSED, @ACTIVE\_OPEN. ACTIVE\_OPEN means when we want to hold off the EAS device we OPEN a relay. ACTIVE\_CLOSED means when we want to hold off the EAS device we CLOSE a relay. Drop down menu and select. This is generally unused and defaults to none.

SERIAL PORT SETUP (set the following – see figure above)

Select Serial button and then drop down and select each item for that port including the port number 1-4 on the MCP400 panel. Baud rate for TFT and SAGE is 9600 and is configurable for the Dasdec for desired setting. Default port is 2.

EAS CRAWL AND NOTIFY (set the following – see figure above)

NOTE: This is only used in Manual Mode setup.

Default settings for position, speed, foreground and background can be changed by dropping down menu items and selecting new entry.

---

The dropdown selection for 'Blink' allows the options of yes and no to be selected. This is whether or not you want the message that appears on the Preset monitor to blink continuously with the message "EAS ALERT COMING DOWN" or not.

In order to use this function you must set up a button in the MCP400 or MCP2020 control panel that can be pressed to run the crawl manually.

To allow the EAS alert blink play manually from a button on the MCP-2020, do the following and drop down the selection arrows to assign:

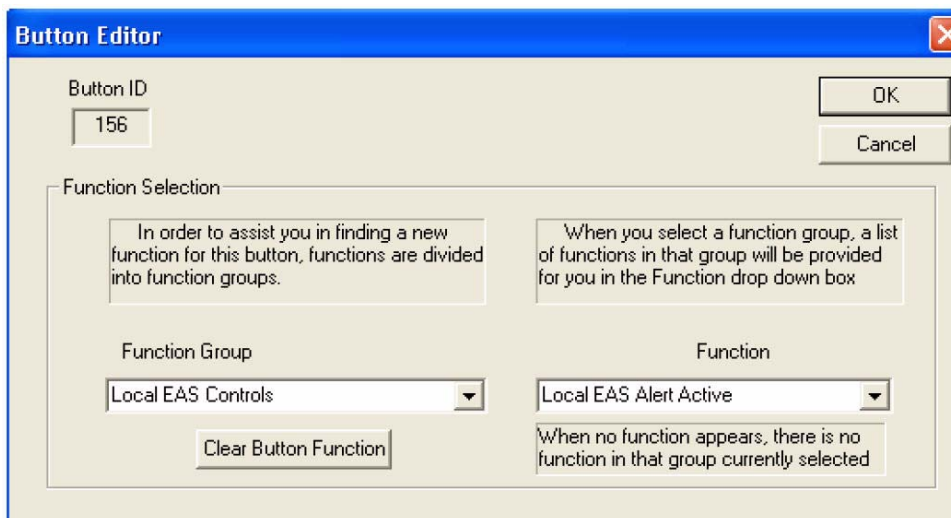

Click on desired button where the manual EAS will be pressed. Then click on the Function Group and Function windows and select the items shown above.

1. Launch the MCPConfig application and click 'Communications' from the top menu item.
2. Click Select Target to Configure and choose the MCP2020.
3. Go to File and click 'Retrieve Configuration from Target'.
4. Click on the button you want to assign as manual EAS.
5. Pick Local EAS Controls from the function group.
6. Pick EAS Alert Active from the function selection.
7. Click OK. Then go to File and click 'Send Configuration to Target'.

---

---

## MACRO SETUP for TFT and DASDEC Models

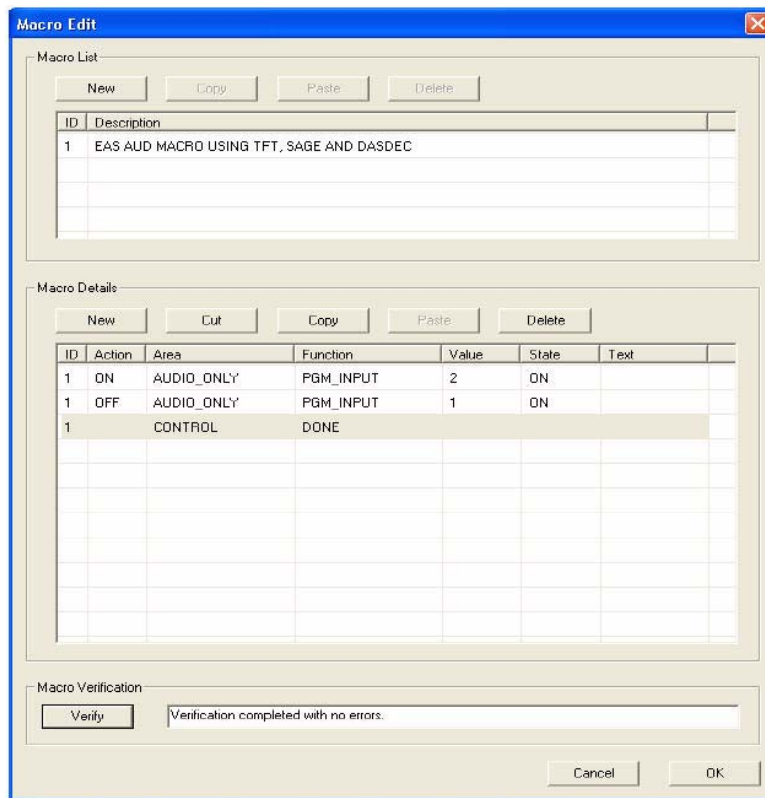

Click on 'MACRO' in the top menu selection in MConfig and select Edit Macros. Set all settings like these for TFT and DASDEC applications.

1. Create new Macro for audio play out by clicking on the button at the top of the table called 'New'. Each time New is clicked it adds a new macro in the description and details tables.
2. Macro 1 needs to be as seen above for the EAS configuration example to work properly. This can be any macro number but must also be changed in the EAS configuration table to correspond to this number.
3. Put a description name of your choice in the top table.
4. Click on the different windows in the bottom table and enter them as seen above. Value 2 is for that button and can be 2-4 of your choice.

---

---

## Macro Setup for Sage Models

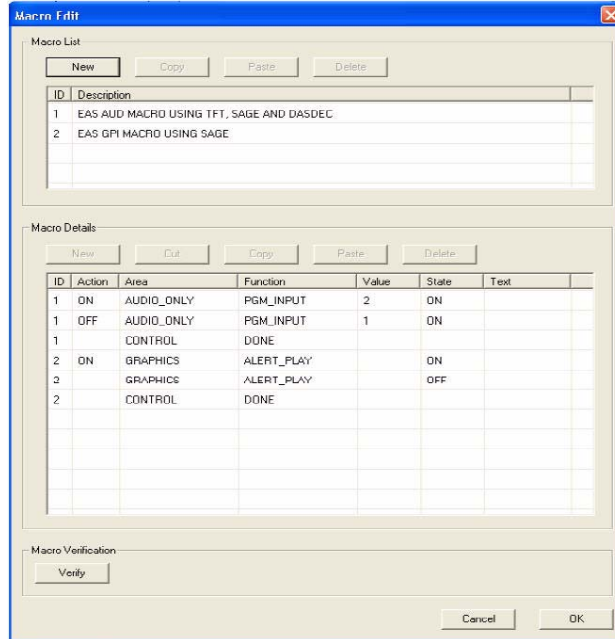

Click on 'MACRO' in the top menu selection in MConfig and select Edit Macros. Set all settings like these for Sage application.

1. Create new Macro for audio play out by clicking on the button at the top of the table called 'New'. Each time New is clicked it adds a new macro in the description and details tables.
2. Macro 1 needs to be as seen above for the EAS configuration example to work properly. This can be any macro number but must also be changed in the EAS configuration table to correspond to this number.
3. Put a description name for macro 1 of your choice in the top table
4. Click on the different windows in the bottom table and enter them as seen above. Value 2 is for that button and can be 2-4 of your choice.
5. Create new macro for Sage to play out properly. This is triggered by a GPI which is described in the next section.
6. Put a description name for macro 2 of your choice in the top table
7. Macro 2 needs to be as seen above for the EAS configuration example to work properly. This can be any macro number but must also be changed in the GPI configuration table to correspond to this number.

---

---

## GPI (Sage setup only)

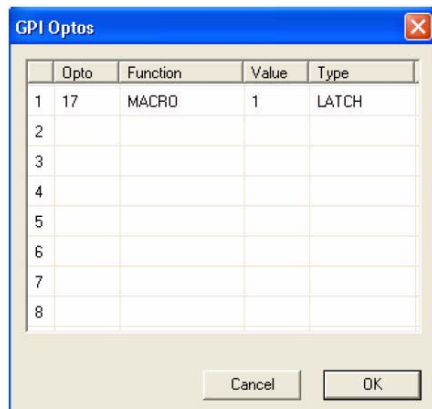

Click on 'Relay/Opto' in the top menu selection in MCConfig and select GPI Optos. Set all settings like these for Sage application.

1. Select GPI Optos from the Relay/Opto menu item.
2. Choose input Opto 17-21 from dropdown menu. Default is 17.
3. Choose Macro function from dropdown as seen above.
4. Enter Macro number for value – default 2 but can be any macro but must make sure the number corresponds to the macro table.
5. Select Latch in the Type dropdown menu.

## AES Input Port (for TFT, Sage and Dasdec TFT)

	Name	Input Group	L1	L2
1	EAS AUD	EXT1	0	1
2	EXT 2	EXT2	0	1
3	EXT 3	EXT3	0	1
4		PGM		

Click on 'Audio' in the top menu selection in MCConfig and select Edit Audio Only Sources. Set all settings like these.

1. From the Audio Only sources type the name you want to have for the EAS audio.

- 
- 
2. Choose the input group connector EXT 1 and put 0 and 1 in the L1 and L2 columns. All others can remain as they are.

## AES Audio Only Buttons (for TFT, Sage and Dasdec TFT)

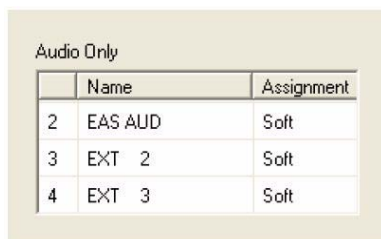

	Name	Assignment
2	EAS AUD	Soft
3	EXT 2	Soft
4	EXT 3	Soft

Click on 'Buttons' in the top menu selection in MCConfig and select Edit Button Assignments. Set all settings like these.

1. Make sure that the name you chose for the audio only is on button 2 and if not then click in the Name window and drop down the menu item and select it from the list.
2. Leave assignments Soft.

## Manual Configuration

Follow the steps for MANUAL SETUP using raw config file.

1. UPGRADE MC-2020 (using procedure 2 above)
  - a. Upgrade the software to sds\_w\_r3-00 or newer.
  - b. Upgrade only the VO firmware to sdfw\_r3-1-ee\_sd525 (ntsc) or sdfw\_r3-1-ee\_sd625(pal) using the burnfw-network-single.bat file
2. UPGRADE MCP-2020 (using procedure 2 above)
  - a. Upgrade the software to mcpsw\_r3-00 or newer.
3. Follow page 2-12 in the System Installation Guide for retrieving the config file from the HD/SD encode folder.
4. Open the Config File xxxx.conf from step 5 and locate the section titled [macro\_definitions\_start]
5. If interfacing to TFT, use the example files below for the TFT macro settings. Note: The default for the audio to play out is macro 1. The button for the audio to run is on button 2 however, this number needs to be whatever button the external audio comes in on. Button 2 is External Input 1, 3 is External Input 2 and 4 is External Input 3.

- 
6. Overwrite the macro section in step 6 with the macro from step 7 for use with a TFT.
  7. If interacting to a SAGE use the example file below for the SAGE macro and GPI settings. (GPI must be 16-21-see SAGE setup below). Note: The default for the audio to play out is macro 1. The button for the audio to run is on button 2 however, this number needs to be whatever button the external audio comes in on. Button 2 is External Input 1, 3 is External Input 2 and 4 is External Input 3.
  8. Overwrite the macro and GPI section in step 6 with the macro and GPI settings from step 9 for use with a SAGE.
  9. For both TFT and SAGE, enter the Macro number for the EAS\_Auto\_Action in Misc Parameters section. This section is at the top of the config file from step 6 above. The number to use is whatever the Macro is from steps 7 or 9 above. The default number is 01. See example below titled "Sample EAS Auto Action". Use the Macro number in the macro\_definition\_start.
  10. You will also need to set the serial port settings in the MC2020 config file to match the TFT or SAGE serial settings. Locate the [Machine\_Control\_Serial\_Port\_Definition\_Start] section in the config file and use the sample below to make the changes to the config file from step 6.
  11. Save & close the config file from step 6 and then run the burn-network.bat file to send changes to HD/SD 2020. CAUTION: This will cause a reset to the 2020 system. Loss of video and audio will occur for up to ten seconds. Proper bypass prior to this step is recommended.
  12. Refer to TFT Manual for how to set up TFT. A short "how to" is provided below.
  13. Refer to Sage Manual for how to set up SAGE. A short "how to" is provided below.

TO ENABLE MANUAL ALERT and trigger from MCP-2020 PANEL.

To have the EAS alert blink a button on the MCP-2020 and to Manual Trigger the alert do the following:

1. Install the version of MCPconfig found on system cd in the install2020 folder. The folder is called release\_mcpconfig.
2. Run MCPconfig.exe
3. Go to Communications/ Specify Target IP Address and port. Set the port to 5580. Click on Ok
4. Go to File and select "Retrieve Configuration from Target"
5. Click on the button you want the manual EAS to be on and the button editor will appear.
6. Drop down the Functions Group list and select Local EAS Controls.
7. Drop down the Function list and select Local EAS Alert Active and then click OK.

- 
- 
8. Under File select "Send Configuration To Target"

#### TFT EAS SETUP FOR MC2020

1. There is only one serial port that can be used on the TFT unit. It needs to be set to 9600, 8 N 1. (see TFT manual for this info or how to set port to these setting if they are not defaults)
2. Run a cross over RS232 cable (pins 2-3, 3-2, 5-5) from the port in step one to serial port 1 on the rear of the MC2020 chassis.
3. In the TFT menu you will need to set the CG type to TFT Standard.

#### SAGE EAS SETUP FOR MC2020

1. Choose one of the Sage serial ports that defaults to 9600, 8 N 1. (see SAGE manual for this info or how to set port to these setting if they are not defaults)
2. Run a cross over RS232 cable (pins 2-3, 3-2, 5-5) from the port in step one to serial port 1 on the rear of the MC2020 chassis.
3. If using an MC2020, locate the Relays/Optos B connector on the rear of the MC2020 and refer to the MC2020 Guide Appendix B for proper pin numbers to be used. The Optos are 16 to 21 on the daughter card. Note: If your system has the 21 relay daughter card this will not work. Contact Utah Scientific to get the card replaced.
4. Run one wire from one side of the GPO on the SAGE connector to one side of the desired GPI in step 3 on the rear of the MC2020.
5. You will need to attach a 5v – 12v supply source between the other side of the GPO on the SAGE and to the other side of the GPI in step 3 on the MC2020.
6. You will also need to put a 1k pull up resistor between the ground and whichever side that wire connects to. This is not built in to the 2020 and will cause damage to the Opto if not installed. See page C-7 in MC2020 guide for detail.
7. In the SAGE menu you will need to locate the serial ports and make sure step 1 above is correct.
8. In the SAGE menu you will need to locate the CG type and make it Generic CG.
9. In the SAGE menu you will need to locate the GPO you are using and set it to PTT.



## Wiring diagram from Utah MC-2020 to Sage

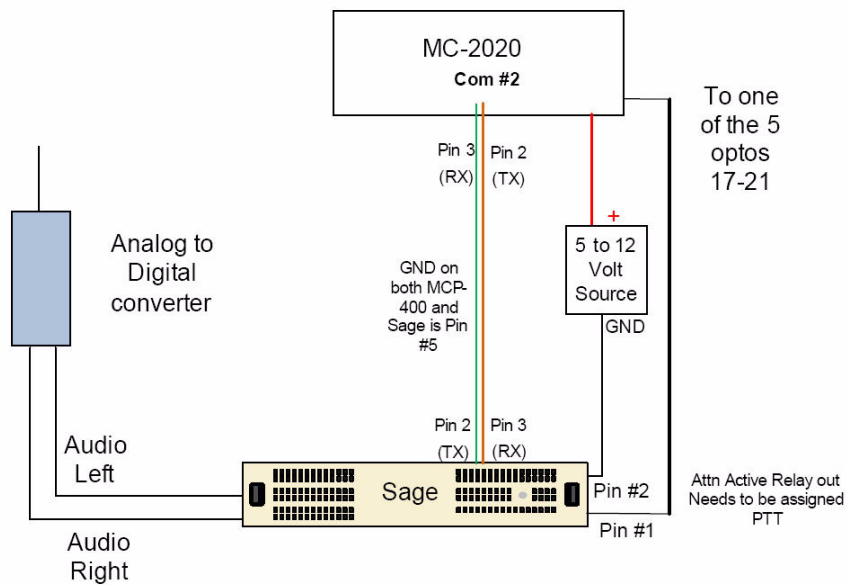

### Config Section Requirements Summary

1. The TFT interface in the MC config file requires 4 sections to be set.
  - a. EAS Auto Action in section [MISC\_START]
  - b. Serial Port configuration in section [MACHINE\_CONTROL\_SERIAL\_PORT\_DEFINITIONS\_START]
  - c. EAS Audio Macro in section [MACRO\_DEFINITIONS\_START]
  - d. EAS Display Options in section [EAS\_DISPLAY\_CONFIG\_DEFINITIONS\_START]
2. The SAGE interface in the MC config requires 6 sections to be set
  - a. EAS Auto Action in section [MISC\_START]
  - b. Serial Port configuration in section [MACHINE\_CONTROL\_SERIAL\_PORT\_DEFINITIONS\_START]
  - c. EAS Audio Macro in section [MACRO\_DEFINITIONS\_START]
  - d. EAS Display Options in section [EAS\_DISPLAY\_CONFIG\_DEFINITIONS\_START]
  - e. EAS Macro for SAGE GPI
  - f. GPI for inbound connection from SAGE GPO programmed as PTT relay

---

---

## Sample TFT Macro

```
[MACRO_DEFINITIONS_START]
#
# This section defines the macros the system can perform.
# See macro-definitions.txt in the software release
# directory for detailed instructions on using macros
#
#NUMBER 1-??
# ,ACTION ON/OFF
# , NUMBER 1-10
# , ,AREA
# , , ,FCN
# , , , ,VALUE
# , , , , ,STATE
# , , , , , ,TEXT8
#4 ,4 , 12 , 12 , 12 ,4 8
#-----,-----,-----,-----,-----
1 ,DESC,EAS AUD MACRO USING TFT
1 ,ON ,AUDIO_ONLY ,PGM_INPUT ,2 ,ON ,
1 ,OFF ,AUDIO_ONLY ,PGM_INPUT ,1 ,ON ,
1 , ,CONTROL ,DONE , , ,
```

---

---

## Sample SAGE Macro and GPI Section Config

```
[MACRO_DEFINITIONS_START]
#
# This section defines the macros the system can perform.
# See macro-definitions.txt in the software release
# directory for detailed instructions on using macros
#
#NUMBER 1-??
# ,ACTION ON/OFF
# , NUMBER 1-10
# , ,AREA
# , , ,FCN
# , , , ,VALUE
# , , , , ,STATE
# , , , , , ,TEXT8
#4 ,4 , 12 , 12 , 12 ,4 8
#-----,-----,-----,-----,-----
1 ,DESC,EAS AUD MACRO
1 ,ON ,AUDIO_ONLY ,PGM_INPUT ,2 ,ON ,
1 ,OFF ,AUDIO_ONLY ,PGM_INPUT ,1 ,ON ,
1 , ,CONTROL ,DONE , , ,
2 ,DESC,EAS GPI MACRO USING SAGE
2 ,ON ,GRAPHICS ,ALERT_PLAY , ,ON ,
2 ,OFF ,GRAPHICS ,ALERT_PLAY , ,OFF ,
2 , ,CONTROL ,DONE , , ,

[GPI_DEFINITIONS_START]
#NUMBER 1-32
# ,AREA
# , ,FCN
# , , ,VALUE
```

---

---

```
# , , ,  
# , , , ,TYPE (LATCH/PULSE)  
#4 , 12 , 12 , 12 , 8  
#--,-----,-----,-----,-----  
16 ,PANEL_MISC ,MACRO ,2 ,LATCH
```

### Sample EAS Auto Action

[MISC\_START]

#Example EAS\_AUTOMATIC\_ACTION: @01

#AUDIO\_CHANNELS:@000F

AUDIO\_DIM\_ADJUST:@-15

VIDEO\_MIX\_POSITION:@08

KEY\_LEVEL\_RESET\_MASK:@0f

KEY\_LEVEL\_XFER\_MASK:@00

TRANS\_SPEED\_FAST:@30

TRANS\_SPEED\_MEDIUM:@60

TRANS\_SPEED\_SLOW:@120

SYSLOG\_SERVER\_ID:@

AUX\_OUT\_XPOINT\_SEL:@PVW

EAS\_AUTOMATIC\_ACTION:@01 (ENTER THE NUMBER FOR THE MACRO)

---

---

## Sample Serial Port Setup for MC2020 Interface to TFT or Sage

```
[MACHINE_CONTROL_SERIAL_PORT_DEFINITIONS_START]
#
# Example config a machine using port 3
# SQZMAX 1,PORT_02 ,38400 ,8 ,NONE ,1 ,DISABLE ,DISABLE
# The system device name is not used programmatically. Just as a reference when
# looking at this file
#
# SYSTEM DEVICE NAME (Don't Care at this time 5/22/2004)
# | , SERIAL COMMUNICATIONS PORT NUMBER
# | | ,BAUD RATE
# | | | ,BITS PER CHARACTER
# | | | | , PARITY TYPE (ODD, EVEN, NONE)
# | | | | | ,STOP BITS PER CHARACTER
# | | | | | ,XONN/OFF FLOW CONTROL (ENABLE/DISABLE)
# | | | | | ,RTS/CTS FLOW CONTROL (ENABLE/DISABLE/RS485???)
#-----,-----,-----,-----,-----,-----,-----,-----
EAS_STD ,PORT_01 ,9600 ,8 ,NONE ,1 ,DISABLE ,DISABLE
```

---

## Sample EAS Display Configuration for TFT

[EAS\_DISPLAY\_CONFIG\_DEFINITIONS\_START]

#

# COLORS. 3 sets of colors are available.

# 1 normal color bars values @ 75%

# 2 normal color bars values @ 100%

# 3 custom colors set by USI

#

# BLACK, WHITE, YELLOW, CYAN, GREEN, MAGENTA, RED, BLUE

# BLACK\_100, WHITE\_100, YELLOW\_100, CYAN\_100, GREEN\_100, MAGENTA\_100,

# RED\_100, BLUE\_100

# TIMEKEY\_FG, TIMEKEY\_BG, NONE, more to come

#

# ### EAS\_CRAWL ###

#

# This line sets the display mode for the crawl messages

# that appear on the PGM output of the MC2020.

#

# EAS\_CRAWL ,YES ,1 ,2 ,1 ,WHITE\_100 ,TIMEKEY\_BG ,NO

#

# ### EAS\_NOTIFY ###

#

# This line sets the display mode for the text messages

# that appear on the MON output of the MC-2020

#

# EAS\_NOTIFY,YES ,1 ,2 ,1 ,WHITE\_100 ,TIMEKEY\_BG ,YES

#

#

#Item (EAS\_CRAWL, EAS\_NOTIFY)

# ,Active (YES/NO)

# , ,Display Line (1 or 8 <1 is top, 8 is bottom>)

---

---

```
#      ,      ,      ,Column (1-40)  <<SPEED 4 CRAWL 1,2,3>>
#      ,      ,      ,Length (1-40)
#      ,      ,      ,      ,FORGROUND COLOR (See above)
#      ,      ,      ,      ,      ,BACKGROUND COLOR...
#      ,      ,      ,      ,      ,      ,BLINK (YES/NO)
# 10   ,4 ,4 ,4 ,4 , 12   , 12   ,4
#-----,---,---,---,---,-----,-----,---
EAS_CRAWL ,YES ,1 ,2 ,1 ,WHITE_100 ,TIMEKEY_BG ,NO
EAS_NOTIFY,YES ,1 ,2 ,1 ,WHITE_100 ,TIMEKEY_BG ,YES
```

---

## Sample EAS Display Configuration for Sage

[EAS\_DISPLAY\_CONFIG\_DEFINITIONS\_START]

#

# COLORS. 3 sets of colors are available.

# 1 normal color bars values @ 75%

# 2 normal color bars values @ 100%

# 3 custom colors set by USI

#

# BLACK, WHITE, YELLOW, CYAN, GREEN, MAGENTA, RED, BLUE

# BLACK\_100, WHITE\_100, YELLOW\_100, CYAN\_100, GREEN\_100, MAGENTA\_100,

# RED\_100, BLUE\_100

# TIMEKEY\_FG, TIMEKEY\_BG, NONE, more to come

#

# ### EAS\_CRAWL ###

#

# This line sets the display mode for the crawl messages

# that appear on the PGM output of the MC2020.

#

# When the background is set to SAGE\_AUTO\_BG, the background

# color of the crawl will be either GREEN, YELLOW, or RED based

# on the type of alert the SAGE has received.

#

# EAS\_CRAWL ,YES ,1 ,2 ,1 ,WHITE\_100 ,SAGE\_AUTO\_BG,NO

#

# This line uses a single color for the background which can

# be used as an alternative to the multi-color background

# if desired by the user.

#

# EAS\_CRAWL ,YES ,1 ,2 ,1 ,WHITE\_100 ,TIMEKEY\_BG ,NO

#

# NOTE: Only one EAS\_CRAWL Line can be active at a time.



---

```

#
#   ### EAS_NOTIFY ###
#
# This line sets the display mode for the text messages
# that appear on the MON output of the MC-2020
#
# EAS_NOTIFY,YES ,1 ,2 ,1 ,WHITE_100 ,TIMEKEY_BG ,YES
#
#Item (EAS_CRAWL, EAS_NOTIFY)
#   ,Active (YES/NO)
#   , , ,Display Line (1 or 8 <1 is top, 8 is bottom>)
#   , , ,Column (1-40)   <<SPEED 4 CRAWL 1,2,3>>
#   , , , ,Length (1-40)
#   , , , , ,FORGROUND COLOR (See above)
#   , , , , , ,BACKGROUND COLOR...
#   , , , , , , ,BLINK (YES/NO)
# 10 ,4 ,4 ,4 ,4 , 12 , 12 ,4
#-----,---,---,---,---,-----,-----,---
EAS_CRAWL ,YES ,1 ,2 ,1 ,WHITE_100 ,SAGE_AUTO_BG,NO
EAS_NOTIFY,YES ,1 ,2 ,1 ,WHITE_100 ,TIMEKEY_BG ,YES

```

---

---

## MC-400 EAS Setup

(This is to be used for setting up the EAS functionality for serial interface and audio Macro play out)

1. Unzip your new CD 3.XX (must be 3.41 or newer) files to C:\USI
2. Go to section 2 of your System Installation Guide



located on this CD for the USI file upgrade procedure.

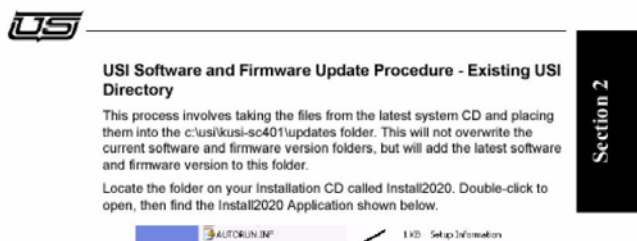

Once you have read through and followed the procedure leading to the Software and Firmware Update Procedure of section 2,

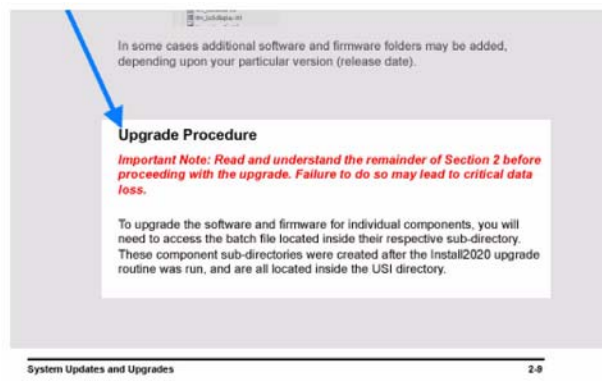

then follow these instructions to configure your system.

---

---

## Configuring System using MConfig Application (for TFT, Sage and Dasdec TFT)

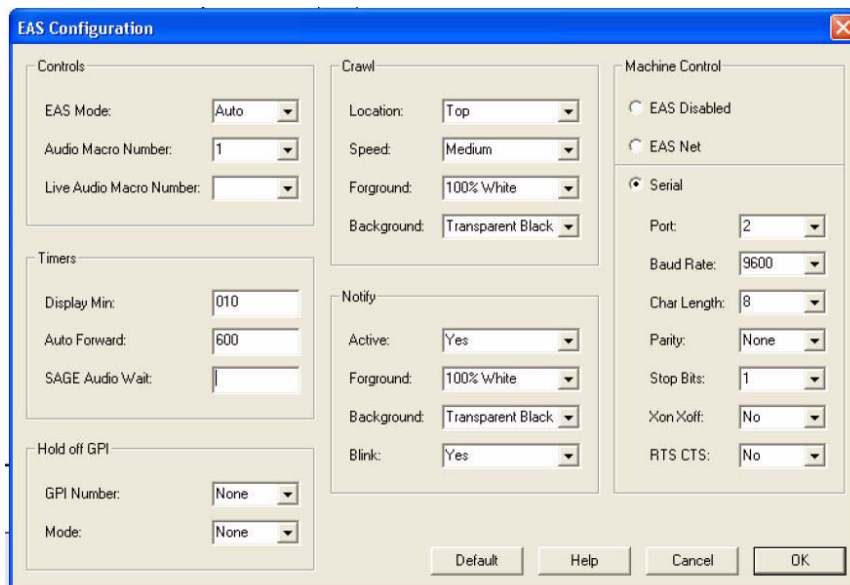

Click on 'EAS' in the top menu selection in MConfig. Set all settings like these for TFT, Sage and Dasdec TFT.

### EAS CONFIGURATION (set the following)

1. EAS MODE selects the mode for EAS operations. AUTO means we automatically forward an EAS Alert - MANUAL means we wait for operator command before we process- OFF means we ignore all inbound EAS commands/actions from the EAS device. Drop down menu and select mode.
2. Audio Macro Number selects the macro number for the audio to run when the EAS comes down. Default setting is 1. Drop down menu to choose correct one.
3. Live Audio Macro Number is used for National Alerts and unless your system runs this it is left at none.
4. DISPLAY MIN sets the minimum time an alert is displayed. Value is in seconds -Valid range is: 10 to 900. Usually a 10. Enter desired value in box.
5. AUTO FORWARD sets the max amount of time that will expire before the MC forces the EAS alert to be played. Valid range is: 10 to 900. Usually set to 600. Enter desired value in box.

- 
- 
6. SAGE AUDIO WAIT sets the max amount of time that will expire before the MC forces the EAS alert to be played. Valid range is: 5 to 900. Enter desired value in box. This is generally unused and defaults to none.
  7. GPI NUMBER is set to the MISC RELAY FUNCTION Number encoded to control the relay attached to the HOLDOFF Function of the EAS device. Drop down menu and select relay number. This is generally unused and defaults to none.
  8. GPI MODE Selects the type of HOLDOFF action used for the EAS device. The options are @, @NONE, @ACTIVE\_CLOSED, @ACTIVE\_OPEN. ACTIVE\_OPEN means when we want to hold off the EAS device we OPEN a relay. ACTIVE\_CLOSED means when we want to hold off the EAS device we CLOSE a relay. Drop down menu and select. This is generally unused and defaults to none.

### **SERIAL PORT SETUP (set the following – see figure above)**

Select Serial button and then drop down and select each item for that port including the port number 1-4 on the MCP400 panel. Baud rate for TFT and SAGE is 9600 and is configurable for the Dasdec for desired setting. Default port is 2.

### **EAS CRAWL AND NOTIFY (set the following – see figure above)**

NOTE: This is only used in Manual Mode setup.

Default settings for position, speed, foreground and background can be changed by dropping down menu items and selecting new entry.

The dropdown selection for 'Blink' allows the options of yes and no to be selected. This is whether or not you want the message that appears on the Preset monitor to blink continuously with the message "EAS ALERT COMING DOWN" or not.

---

In order to use this function you must set up a button in the MCP400 or MCP2020 control panel that can be pressed to run the crawl manually.

To have the EAS alert blink play manually from a button on the MCP-2020 do the following and drop down the selection arrows to assign:

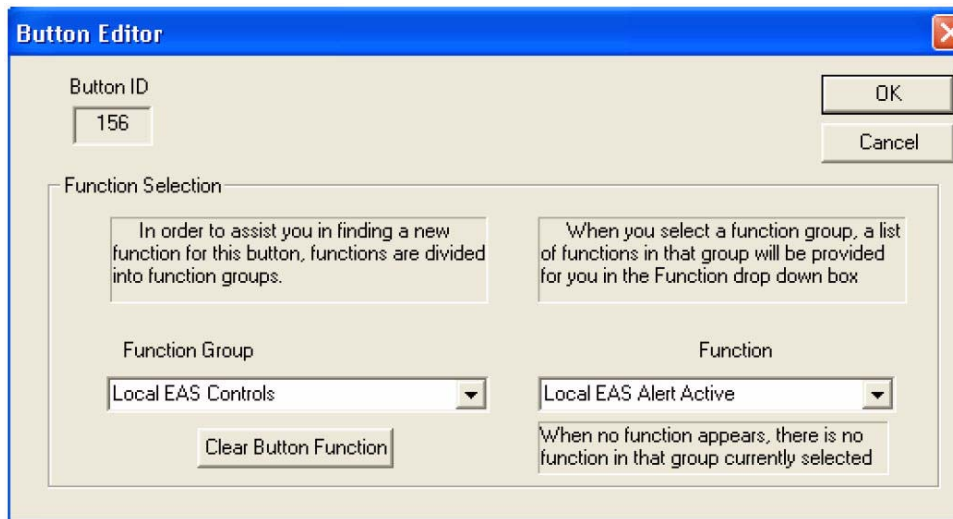

Click on desired button where the manual EAS will be pressed. Then click on the Function Group and Function windows and select the items shown above.

1. Launch the MCPConfig application and click 'Communications' from the top menu item.
2. Click Select Target to Configure and choose the MCP2020.
3. Go to File and click 'Retrieve Configuration from Target'.
4. Click on the button you want to assign as manual EAS.
5. Pick Local EAS Controls from the function group.
6. Pick EAS Alert Active from the function selection.
7. Click OK. Then go to File and click 'Send Configuration to Target'.

---

To have the EAS play manually from a button on the MCP-400 do the following:

1. Perform the getencode.bat script file from c:\usi\xxxx-mcp40001 and open the xxxx-mcp40001.conf file.
2. Edit button 0116 line to be 0116,0046,0001, LOCAL EAS CONTROL and then save and close the file.
3. Perform the burnenc-network.bat script file to burn the config file back to the MCP-400.

## MACRO SETUP for TFT and DASDEC Models

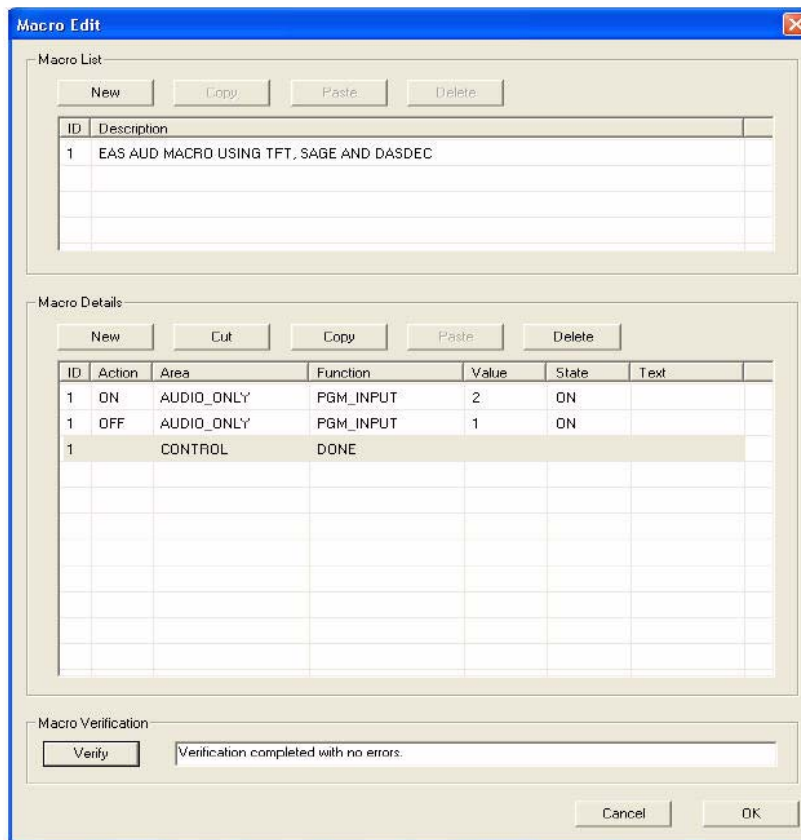

Click on 'MACRO' in the top menu selection in MConfig and select Edit Macros. Set all settings like these for TFT and DASDEC applications.

1. Create new Macro for audio play out by clicking on the button at the top of the table called 'New'. Each time New is clicked it adds a new macro in the description and details tables.
2. Macro 1 needs to be as seen above for the EAS configuration example to work properly. This can be any macro number but must also be changed in the EAS configuration table to correspond to this number.
3. Put a description name of your choice in the top table
4. Click on the different windows in the bottom table and enter them as seen above.

## MACRO SETUP for Sage Models

The screenshot shows the 'Macro Edit' dialog box with two main sections: 'Macro List' and 'Macro Details'.

**Macro List:**

ID	Description
1	EAS AUD MACRO USING TFT, SAGE AND DASDEC
2	EAS GPI MACRO USING SAGE

**Macro Details:**

ID	Action	Area	Function	Value	State	Text
1	ON	AUDIO_ONLY	PGM_INPUT	2	ON	
1	OFF	AUDIO_ONLY	PGM_INPUT	1	ON	
1		CONTROL	DONE			
2	ON	GRAPHICS	ALERT_PLAY		ON	
2		GRAPHICS	ALERT_PLAY		OFF	
2		CONTROL	DONE			

**Macro Verification:**

Verify

Cancel OK

Click on 'MACRO' in the top menu selection in MCCConfig and select Edit Macros. Set all settings like these for Sage application.

1. Create new Macro for audio play out by clicking on the button at the top of the table called 'New'. Each time New is clicked it adds a new macro in the description and details tables.
2. Macro 1 needs to be as seen above for the EAS configuration example to work properly. This can be any macro number but must also be changed in the EAS configuration table to correspond to this number.
3. Put a description name for macro 1 of your choice in the top table
4. Click on the different windows in the bottom table and enter them as seen above.
5. Create new macro for Sage to play out properly. This is triggered by a GPI which is described in the next section.
6. Put a description name for macro 2 of your choice in the top table
7. Macro 2 needs to be as seen above for the EAS configuration example to work properly. This can be any macro number but must also be changed in the GPI configuration table to correspond to this number.

### GPI (Sage setup only)



Click on 'Relay/Opto' in the top menu selection in MCCConfig and select GPI Optos. Set all settings like these for Sage application.

1. Select GPI Optos from the Relay/Opto menu item.
2. Choose input Opto 1-8 from dropdown menu. Default is 8.



- 
- 
3. Choose Macro function from dropdown as seen above.
  4. Enter Macro number for value – default 2 but can be any macro but must make sure the number corresponds to the macro table.
  5. Select Latch in the Type dropdown menu.

### **AES INPUT PORT (for TFT, Sage and Dasdec TFT)**



	Name	Input Group	L1	L2	L3
1	AESRTR	EXT1	2	3	
2	AESBNC	EXT1	0	1	
3		PGM			
4		PGM			

Click on 'Audio' in the top menu selection in MConfig and select Edit Audio Only Sources. Set all settings like these.

1. From the Audio Only sources make sure the name for AESRTR is set for level numbers 2 and 3 and that AESBNC is set for numbers 0 and 1.
2. Choose the input group connector EXT 1 for both.

---

## AES AUDIO ONLY BUTTONS (for TFT, Sage and Dasdec TFT)

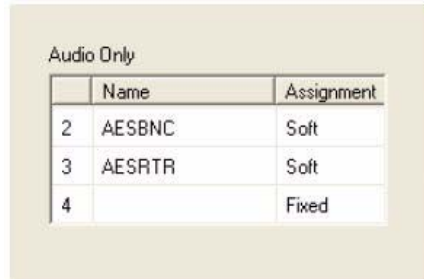

	Name	Assignment
2	AESBNC	Soft
3	AESRTR	Soft
4		Fixed

Click on 'Buttons' in the top menu selection in MConfig and select Edit Button Assignments. Set all settings like these.

1. Make sure that the AESBNC is on button 2 and if not then click in the Name window and drop down the menu item and select it from the list. AESRTR should be on button 3.
2. Leave assignments Soft.

## Configuring DASDEC for EAS Net using MConfig Application (Currently only DASDEC uses this and only MC400 models)

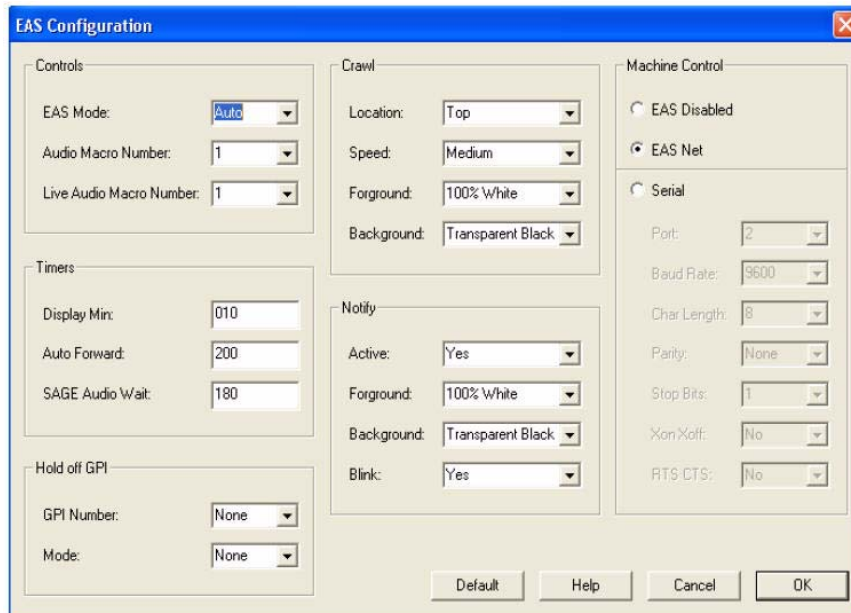

**EAS Configuration**

**Controls**

EAS Mode: Auto  
Audio Macro Number: 1  
Live Audio Macro Number: 1

**Timers**

Display Min: 010  
Auto Forward: 200  
SAGE Audio Wait: 180

**Hold off GPI**

GPI Number: None  
Mode: None

**Crawl**

Location: Top  
Speed: Medium  
Foreground: 100% White  
Background: Transparent Black

**Notify**

Active: Yes  
Foreground: 100% White  
Background: Transparent Black  
Blink: Yes

**Machine Control**

EAS Disabled  
 EAS Net

Serial

Port: 2  
Baud Rate: 9600  
Char Length: 8  
Parity: None  
Stop Bits: 1  
Xon/Xoff: No  
RTS/CTS: No

Default Help Cancel OK

Click on 'EAS' in the top menu selection in MConfig. Set all settings like these for EAS Net.

---

---

## **EAS CONFIGURATION (set the following)**

1. EAS MODE selects the mode for EAS operations. AUTO means we automatically forward an EAS Alert - MANUAL means we wait for operator command before we process- OFF means we ignore all inbound EAS commands/actions from the EAS device. Drop down menu and select mode.
2. Audio Macro Number selects the macro number for the audio to run when the EAS comes down. Default setting is 1. Drop down menu to choose correct one.
3. Live Audio Macro Number is used for National Alerts and unless your system runs this it is left at none.
4. DISPLAY MIN sets the minimum time an alert is displayed. Value is in seconds -Valid range is: 10 to 900. Usually a 10. Enter desired value in box.
5. AUTO FORWARD sets the max amount of time that will expire before the MC forces the EAS alert to be played. Valid range is: 10 to 900. Usually set to 600. Enter desired value in box.
6. SAGE AUDIO WAIT sets the max amount of time that will expire before the MC forces the EAS alert to be played. Valid range is: 5 to 900. Enter desired value in box. This is generally unused and defaults to none.
7. GPI NUMBER is set to the MISC RELAY FUNCTION Number encoded to control the relay attached to the HOLDOFF Function of the EAS device. Drop down menu and select relay number. This is generally unused and defaults to none.
8. GPI MODE Selects the type of HOLDOFF action used for the EAS device. The options are @, @NONE, @ACTIVE\_CLOSED, @ACTIVE\_OPEN. ACTIVE\_OPEN means when we want to hold off the EAS device we OPEN a relay. ACTIVE\_CLOSED means when we want to hold off the EAS device we CLOSE a relay. Drop down menu and select. This is generally unused and defaults to none.
9. Select EAS NET button. This will disable the serial port and set it up for network use.

## **EAS CRAWL AND NOTIFY (set the following – see figure above)**

NOTE: This is only used in Manual Mode setup.

Default settings for position, speed, foreground and background can be changed by dropping down menu items and selecting new entry.

The dropdown selection for 'Blink' allows the options of yes and no to be selected. This is whether or not you want the message that appears on the Preset monitor to blink continuously with the message "EAS ALERT COMING DOWN" or not.

In order to use this function you must set up a button in the MCP400 or MCP2020 control panel that can be pressed to run the crawl manually.

---

To have the EAS alert blink play manually from a button on the MCP-2020 do the following and drop down the selection arrows to assign:

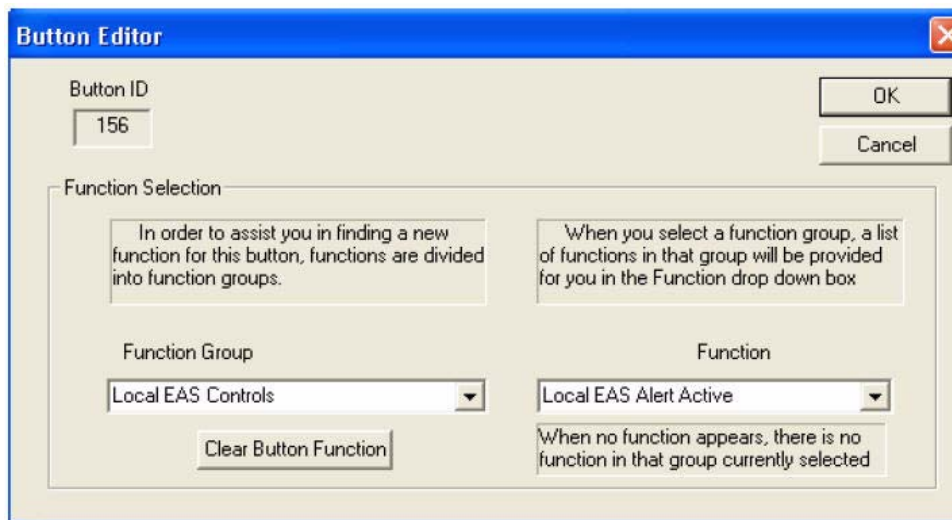

Click on desired button where the manual EAS will be pressed. Then click on the Function Group and Function windows and select the items shown above.

1. Launch the MCPConfig application and click 'Communications' from the top menu item.
2. Click Select Target to Configure and choose the MCP2020.
3. Go to File and click 'Retrieve Configuration from Target'.
4. Click on the button you want to assign as manual EAS.
5. Pick Local EAS Controls from the function group.
6. Pick EAS Alert Active from the function selection.
7. Click OK. Then go to File and click 'Send Configuration to Target'.

To have the EAS play manually from a button on the MCP-400 do the following:

1. Perform the getencode.bat script file from c:\usi\xxx-mcp40001 and open the xxx-mcp40001.conf file.
2. Edit button 0116 line to be 0116,0046,0001, LOCAL EAS CONTROL and then save and close the file.
3. Perform the burnenc-network.bat script file to burn the config file back to the MCP-400.

---

## MACRO SETUP for DASDEC EAS Net

Macro Edit

Macro List

New Copy Paste Delete

ID	Description
1	EAS AUD MACRO USING TFT, SAGE AND DASDEC

Macro Details

New Cut Copy Paste Delete

ID	Action	Area	Function	Value	State	Text
1	ON	AUDIO_ONLY	PGM_INPUT	4	ON	
1	OFF	AUDIO_ONLY	PGM_INPUT	1	ON	
1		CONTROL	DONE			

Macro Verification

Verify Verification completed with no errors.

Cancel OK

Click on 'MACRO' in the top menu selection in MConfig and select Edit Macros. Set all settings like these for EAS Net applications.

1. Create new Macro for audio play out by clicking on the button at the top of the table called 'New'. Each time New is clicked it adds a new macro in the description and details tables.

2. Macro 1 needs to be as seen above for the EAS configuration example to work properly. This can be any macro number but must also be changed in the EAS configuration table to correspond to this number.
3. Put a description name of your choice in the top table
4. Click on the different windows in the bottom table and enter them as seen above.

### AES INPUT PORT for Dasdec - (setup in Audio source and btns)

Edit Audio Only Sources					
	Name	Input Group	L1	L2	L3
1	AESRTR	EXT1	2	3	
2	AESBNC	EXT1	0	1	
3	_MP_ 3	PVWE	0	1	
4		PGM			

Click on 'Audio' in the top menu selection in MCCConfig and select Edit Audio Only Sources. Set all settings like these.

1. From the Audio Only sources make sure the name \_MP\_ 3 is set with numbers 0 and 1 in the L1 and L2 columns.
2. Choose the input group connector PVWE.

### AES AUDIO ONLY BUTTONS (for TFT, Sage and Dasdec TFT)

Audio Only		
	Name	Assignment
2	AESBNC	Soft
3	AESRTR	Soft
4	_MP_ 3	Soft

Click on 'Buttons' in the top menu selection in MCCConfig and select Edit Button Assignments. Set all settings like these.

- 
1. Make sure that the `_MP_3` is on button 2 and if not then click in the Name window and drop down the menu item and select it from list.
  2. Leave assignment Soft.

## MANUAL CONFIGURATION

Follow the steps for MANUAL SETUP using raw config file.

1. Follow page 2-12 in the System Installation Guide for retrieving config file from the MC400 encode folder.
2. Open the Config File `xxxx.conf` from step 3 and locate the section titled `[macro_definitions_start]`
3. If interfacing to TFT, use the example files below for the TFT macro settings. Note: The default for the audio to play out is macro 1. The button for the audio to run is on button 3.
4. Overwrite the macro section in step 4 with the macro from step 5 for use with a TFT.
5. If interacting to a SAGE use the example file below for the SAGE macro and GPI settings. (GPI can be 1-8 -see SAGE setup below). Note: The default for the audio to play out is macro 1. The button for the audio to run is on button 3.
6. Overwrite the macro and GPI section in step 4 with the macro and GPI settings from step 7 for use with a SAGE.
7. For both TFT and SAGE, enter the Macro number for the `EAS_Auto_Action` in Misc Parameters section. This section is at the top of the config file from step 4 above. The number to use is whatever the Macro is from steps 5 or 7 above. The default number is 01. See example below titled "Sample EAS Auto Action". Use the Macro number in the `macro_definition_start`.
8. For TFT use the Manual or Auto mode for the Operation Mode in the Misc Parameters Section. For SAGE use Manual mode only for the Operation Mode in the Misc Parameters section.
9. You will also need to set the serial port settings in the MC400 config file to match the TFT or SAGE serial settings. Locate the `[Machine_Control_Serial_Port_Definition_Start]` section in the config file and use the sample below to make the changes to the config file from step 4.
10. Save & close the config file from step 4 and then run the `burn-network.bat` file to send changes to both the MC400 and MCP400 devices. CAUTION: This will cause a reset to the MC400 system. Loss of video and audio will occur for up to ten seconds. Proper bypass prior to this step is recommended.
11. Refer to TFT Manual for how to set up TFT. A short "how to" is provided below.
12. Refer to Sage Manual for how to set up SAGE. A short "how to" is provided below.

---

## **TO ENABLE MANUAL ALERT and trigger from MCP-400 PANEL**

To have the EAS alert blink a button on the MCP-400 and to Manual Trigger the alert do the following:

1. Perform the getencode.bat script file from c:\usi\xxxx-mcp40001 and open the xxxx-mcp40001.conf file.
2. Edit button 0116 line to be 0116,0046,0001, LOCAL EAS CONTROL and then save and close the file.
3. Perform the burnenc-network.bat script file to burn the config file back to the MCP-400.

## **TFT EAS SETUP FOR MC400**

1. There is only one serial port that can be used on the TFT unit. It needs to be set to 9600, 8 N 1. (see TFT manual for this info or how to set port to these setting if they are not defaults)
2. Run a cross over RS232 cable (pins 2-3, 3-2, 5-5) from the port in step one to serial port 1 on the rear of the MCP400 or MCP400i unit.
3. In the TFT menu you will need to set the CG type to TFT Standard.

## **SAGE EAS SETUP FOR MC400**

1. Choose one of the Sage serial ports that defaults to 9600, 8 N 1. (see SAGE manual for this info or how to set port to these setting if they are not defaults)
2. Run a cross over RS232 cable (pins 2-3, 3-2, 5-5) from the port in step one to serial port 1 on the rear of the MCP400 or MCP400i unit.
3. Locate the Relays/Optos connector on the rear of the MCP400 or MCP400i and refer to the MC40/400 for proper pin numbers to be used. The Optos are 1 - 8 on the rear of the panel. The default below is set to use GPI 8.
4. Run one wire from one side of the GPO on the SAGE connector to one side of the desired GPI in step 3 on the rear of the MCP400.
5. You will need to attach a 5v – 12v supply source between the other side of the GPO on the SAGE and to the other side of the GPI in step 3 on the MCP400.
6. In the SAGE menu you will need to locate the serial ports and make sure step 1 above is correct.
7. In the SAGE menu you will need to locate the CG type and make it Generic CG.
8. In the SAGE menu you will need to locate the GPO you are using and set it to PTT.



---

---

### Wiring diagram from Utah Masters to Sage

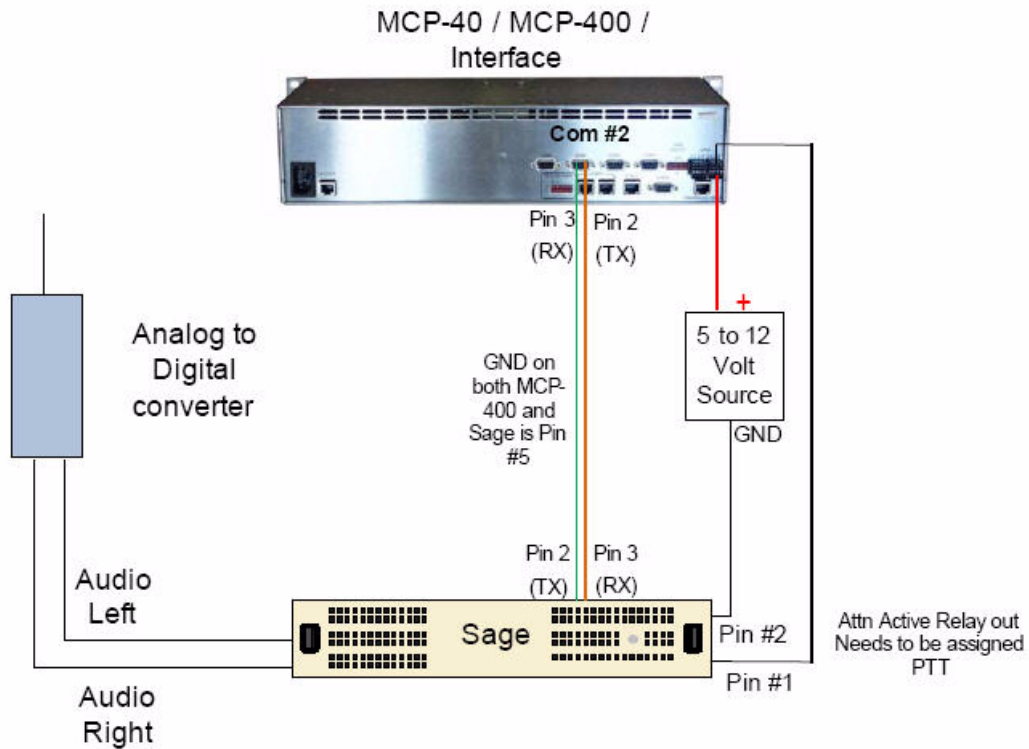

### CONFIG SECTION REQUIREMENTS SUMMARY

1. The TFT interface in the MC config file requires 4 sections to be set.
  - a. EAS Auto Action in section [MISC\_START]
  - b. Serial Port configuration in section [MACHINE\_CONTROL\_SERIAL\_PORT\_DEFINITIONS\_START]
  - c. EAS Audio Macro in section [MACRO\_DEFINITIONS\_START]
  - d. EAS Display Options in section [EAS\_DISPLAY\_CONFIG\_DEFINITIONS\_START]
2. The SAGE interface in the MC config requires 6 sections to be set
  - a. EAS Auto Action in section [MISC\_START] (Must be Manual mode)

- 
- b. Serial Port configuration in section [MACHINE\_CONTROL\_SERIAL\_PORT\_DEFINITIONS\_START]
  - c. EAS Audio Macro in section [MACRO\_DEFINITIONS\_START]
  - d. EAS Display Options in section [EAS\_DISPLAY\_CONFIG\_DEFINITIONS\_START]
  - e. EAS Macro for SAGE GPI
  - f. GPI for inbound connection from SAGE GPO programmed as PTT relay.

### Sample TFT Macro

```
[MACRO_DEFINITIONS_START]
#
# This section defines the macros the system can perform.
# See macro-definitions.txt in the software release
# directory for detailed instructions on using macros
#
#NUMBER 1-??
# ,ACTION ON/OFF
# , NUMBER 1-10
# , ,AREA
# , , ,FCN
# , , , ,VALUE
# , , , , ,STATE
# , , , , ,TEXT8
#4 ,4 , 12 , 12 , 12 ,4 8
#---,---,-----,-----,-----,---,-----
1 ,DESC,EAS AUD MACRO USING TFT
1 ,ON ,AUDIO_ONLY ,PGM_INPUT ,2 ,ON ,
1 ,OFF ,AUDIO_ONLY ,PGM_INPUT ,1 ,ON ,
1 , ,CONTROL ,DONE , , ,
```

---

---

## Sample SAGE Macro and GPI Section Config

```
[MACRO_DEFINITIONS_START]
#
# This section defines the macros the system can perform.
# See macro-definitions.txt in the software release
# directory for detailed instructions on using macros
#
#NUMBER 1-??
# ,ACTION ON/OFF
# , NUMBER 1-10
# , ,AREA
# , , ,FCN
# , , , ,VALUE
# , , , , ,STATE
# , , , , , ,TEXT8
#4 ,4 , 12 , 12 , 12 ,4 8
#-----,-----,-----,-----,-----
1 ,DESC,EAS AUD MACRO
1 ,ON ,AUDIO_ONLY ,PGM_INPUT ,2 ,ON ,
1 ,OFF ,AUDIO_ONLY ,PGM_INPUT ,1 ,ON ,
1 , ,CONTROL ,DONE , , ,
2 ,DESC,EAS GPI MACRO USING SAGE
2 ,ON ,GRAPHICS ,ALERT_PLAY , ,ON ,
2 ,OFF ,GRAPHICS ,ALERT_PLAY , ,OFF ,
2 , ,CONTROL ,DONE , , ,

[GPI_DEFINITIONS_START]
#NUMBER 1-32
# ,AREA
# , ,FCN
# , , ,VALUE
```

---

---

```
# , , ,
# , , , ,TYPE (LATCH/PULSE)
#4 , 12 , 12 , 12 , 8
#--,-----,-----,-----,-----
8 ,PANEL_MISC ,MACRO ,2 ,LATCH
```

### Sample EAS Auto Action and Operation Mode

[MISC\_START]

#Example EAS\_AUTOMATIC\_ACTION: @01

#AUDIO\_CHANNELS:@000F

AUDIO\_DIM\_ADJUST:@-15

VIDEO\_MIX\_POSITION:@08

KEY\_LEVEL\_RESET\_MASK:@0f

KEY\_LEVEL\_XFER\_MASK:@00

TRANS\_SPEED\_FAST:@30

TRANS\_SPEED\_MEDIUM:@60

TRANS\_SPEED\_SLOW:@120

SYSLOG\_SERVER\_ID:@

AUX\_OUT\_XPOINT\_SEL:@PVW

EAS\_AUTOMATIC\_ACTION:@01 (ENTER THE NUMBER FOR THE MACRO)

CLEANSWITCH\_ENABLED:@NO

INDIVIDUAL\_RATIOS:@NO

MC400\_LINE\_STANDARD:@SD\_525

EAS\_OPERATION\_MODE:@MANUAL(SAGE must be MANUAL,TFT AUTO or MANUAL)

EAS\_DISPLAY\_TIME\_MIN:@015

EAS\_FORWARD\_TIMEOUT:@600

---

---

## Sample Serial Port Setup for MC400 Interface to TFT or Sage

```
[MACHINE_CONTROL_SERIAL_PORT_DEFINITIONS_START]
#
# Example config a machine using port 3
# SQZMAX 1,PORT_02 ,38400 ,8 ,NONE ,1 ,DISABLE ,DISABLE
# The system device name is not used pragmatically. Just as a reference when
# looking at this file
#
# SYSTEM DEVICE NAME (Don't Care at this time 5/22/2004)
# | , SERIAL COMMUNICATIONS PORT NUMBER
# | | ,BAUD RATE
# | | | ,BITS PER CHARACTER
# | | | | , PARITY TYPE (ODD, EVEN, NONE)
# | | | | | ,STOP BITS PER CHARACTER
# | | | | | ,XONN/OFF FLOW CONTROL (ENABLE/DISABLE)
# | | | | | ,RTS/CTS FLOW CONTROL (ENABLE/DISABLE/RS485???)
#-----,-----,-----,-----,-----,-----,-----,-----
EAS_STD ,PORT_01 ,9600 ,8 ,NONE ,1 ,DISABLE ,DISABLE
```

## Sample EAS Display Configuration for TFT

```
[EAS_DISPLAY_CONFIG_DEFINITIONS_START]
#
# COLORS. 3 sets of colors are available.
# 1 normal color bars values @ 75%
# 2 normal color bars values @ 100%
# 3 custom colors set by USI
#
# BLACK, WHITE, YELLOW, CYAN, GREEN, MAGENTA, RED, BLUE
# BLACK_100, WHITE_100, YELLOW_100, CYAN_100, GREEN_100, MAGENTA_100,
# RED_100, BLUE_100
# TIMEKEY_FG, TIMEKEY_BG, NONE, more to come
```

---

```

#
#   ### EAS_CRAWL ###
#
# This line sets the display mode for the crawl messages
# that appear on the PGM output of the MC2020.
#
# EAS_CRAWL ,YES ,1 ,2 ,1 ,WHITE_100 ,TIMEKEY_BG ,NO
#
#   ### EAS_NOTIFY ###
#
# This line sets the display mode for the text messages
# that appear on the MON output of the MC-2020
#
# EAS_NOTIFY,YES ,1 ,2 ,1 ,WHITE_100 ,TIMEKEY_BG ,YES
#
#
#Item (EAS_CRAWL, EAS_NOTIFY)
#   ,Active (YES/NO)
#   , , ,Display Line (1 or 8 <1 is top, 8 is bottom>)
#   , , ,Column (1-40)  <<SPEED 4 CRAWL 1,2,3>>
#   , , , ,Length (1-40)
#   , , , , ,FORGROUND COLOR (See above)
#   , , , , , ,BACKGROUND COLOR...
#   , , , , , , ,BLINK (YES/NO)
# 10 ,4 ,4 ,4 ,4 , 12 , 12 ,4
#-----,---,---,---,---,-----,-----,---
EAS_CRAWL ,YES ,1 ,2 ,1 ,WHITE_100 ,TIMEKEY_BG ,NO
EAS_NOTIFY,YES ,1 ,2 ,1 ,WHITE_100 ,TIMEKEY_BG ,YES

```

---

---

## Sample EAS Display Configuration for Sage

```
[EAS_DISPLAY_CONFIG_DEFINITIONS_START]
#
# COLORS. 3 sets of colors are available.
#     1 normal color bars values @ 75%
#     2 normal color bars values @ 100%
#     3 custom colors set by USI
#
# BLACK, WHITE, YELLOW, CYAN, GREEN, MAGENTA, RED, BLUE
# BLACK_100, WHITE_100, YELLOW_100, CYAN_100, GREEN_100, MAGENTA_100,
# RED_100, BLUE_100
# TIMEKEY_FG, TIMEKEY_BG, NONE, more to come
#
#     ### EAS_CRAWL ###
#
# This line sets the display mode for the crawl messages
# that appear on the PGM output of the MC2020.
#
# When the background is set to SAGE_AUTO_BG, the background
# color of the crawl will be either GREEN, YELLOW, or RED based
# on the type of alert the SAGE has received.
#
# EAS_CRAWL ,YES ,1 ,2 ,1 ,WHITE_100 ,SAGE_AUTO_BG,NO
#
# This line uses a single color for the background which can
# be used as an alternative to the multi-color background
# if desired by the user.
#
# EAS_CRAWL ,YES ,1 ,2 ,1 ,WHITE_100 ,TIMEKEY_BG ,NO
#
# NOTE: Only one EAS_CRAWL Line can be active at a time.
```

---

```

#
#   ### EAS_NOTIFY ###
#
# This line sets the display mode for the text messages
# that appear on the MON output of the MC-2020
#
# EAS_NOTIFY,YES ,1 ,2 ,1 ,WHITE_100 ,TIMEKEY_BG ,YES
#
#Item (EAS_CRAWL, EAS_NOTIFY)
#   ,Active (YES/NO)
#   , ,Display Line (1 or 8 <1 is top, 8 is bottom>)
#   , , ,Column (1-40)  <<SPEED 4 CRAWL 1,2,3>>
#   , , , ,Length (1-40)
#   , , , , ,FORGROUND COLOR (See above)
#   , , , , , ,BACKGROUND COLOR...
#   , , , , , , ,BLINK (YES/NO)
# 10 ,4 ,4 ,4 ,4 ,4 , 12 , 12 ,4
#-----,---,---,---,---,-----,-----,---
EAS_CRAWL ,YES ,1 ,2 ,1 ,WHITE_100 ,SAGE_AUTO_BG,NO
EAS_NOTIFY,YES ,1 ,2 ,1 ,WHITE_100 ,TIMEKEY_BG ,YES

```





---

# Appendix G

## UCP Version Upgrade Procedure

### Checking the Current Version - UCP Panel

(This procedure must be done using a serial connection to the diagnostic port on the UCP panel)

1. Connect the 9 pin serial port on the PC running TeraTerm to the RJ-45 to 9 pin adapter (9 pin side) provided by Utah Scientific (labeled SC4/2020).

***NOTE: if this is a laptop from Utah Scientific then connect to the 9 pin serial port on the USB to serial cable provided with the laptop.***

2. Connect the UCP diagnostic serial port to the RJ-45 to 9 pin adapter (RJ45 side) provided by Utah Scientific (labeled SC4/2020) using a standard straight through CAT 5 cable.
3. Launch Tera Term Pro and open the Setup menu and select 'Serial Port'.
4. Select the computer COMM port that is being used.
5. Set the baud rate to 19200.
6. Set the Data to 8 bit.
7. Set the Parity to None.
8. Set the Stop to 1 bit.
9. Set Flow Control to None.
10. Click OK.

11. At the prompt you should see the Node number of the panel you are connected to.
12. Type the letter V and then press 'Return' to see the current version.
13. Close Tera Term before performing the upgrade.

## Upgrade Procedure

(Use this procedure for all UCP panel types)

1. Navigate to the folder called release-ucp found on the system CD and open it.
2. Double click the setup.bat file. This will create a new folder called ucp located in C:\usi.
3. Open the new folder from step 2 and then open the folder with the highest version number. (Example: v1.93)
4. Make sure there are no sessions of TeraTerm running at this time and then open the Unic807 folder and double click the UcpUpgrade.bat file.

***NOTE: The only time the Unic803 folder is to be used is if there are UCP-64 style control panels that need to be upgraded. In this case refer to the next section for the procedure.***

5. The upgrade will run automatically from here and prompt you that it is done.
6. Use the procedure above to check that the new version has been loaded successfully.

## Upgrade Procedure for UCP-64 Style Panels with the UNIC803 Chip Set

(Use this procedure only for UCP-64 panel types)

1. Use the procedure above for checking the version type.
2. After typing the letter V you will see the version number and at the end of that line it will either have an 803 or an 807 which is the chip type.
3. If it is an 803 then follow the same upgrade procedure found above only in step 4 open the Unic803 folder and proceed from there.

---

---

## Index

### Numerics

- 10 X 10 matrix 1-8
- 10 X 10 switching matrix 1-6
- 80229-10 MX-Bus cable 3-8
- 80263-2 U-Net hub 3-6
- 80263-5 U-Net hub with -48 VDC power pack 3-6

### A

- Adjusting Timing E-4
- AES AUDIO ONLY BUTTONS F-28, F-32
- AES Audio Only Buttons F-8
- AES INPUT PORT F-27
  - Dasdec F-32
- AES Input Port F-7
- Analog Audio 1-8
- Analog Video 1-8
- Application
  - Log Analyzer 5-17
- Asynchronous Video E-2
- Auto Take
  - system logging example 5-25
- Automation
  - company details (system logging) 5-28

### B

- Background On 6-5
- Basic System Layout 1-5
- Batchfile Description Table 1-52
- board numbers and versions
  - checking D-1
- breakaway takes 1-6
- Burn Encoding 1-45, 4-3
- Burn Firmware 1-45, 4-3
- Burn Logos 1-46, 4-4
- Burn Software 1-45, 4-3
- Burn SW / FW Set 1-45, 4-3

### C

- Chassis Operations 1-48, 4-6
- Checking the Current Version G-1
- communication ports
  - SC-3 rear panel
    - MX 3-8
- configuration file information D-1
- Configuration PC 1-5
- Configure Script Addresses 1-47, 4-5

- Control Panels 1-5
- Controllers 1-5
- crossover cable
  - for direct Ethernet connection to an RMS panel 3-10
- current device settings
  - displaying D-1

### D

- Daisy Chain Configuration 3-4
- Daisy Chain configuration
  - RJ-45 connectors 3-4
- daisy-chained SCP panels in a U-Net topology 3-3
- data parsing 5-8
- Debug 2020 utility
  - system logging 5-29
- Debug information
  - displaying D-1
- Default Log Server
  - system logging 5-5
- Device IP Address Identification 2-2
- Device Software Lookup 2-1, D-8
- Diagnostic Port
  - quick commands D-1
- Digital Audio 1-8
- Digital Video 1-8
- Directory Removal A-5
- Displaying a logo 6-7

### E

- EAS CONFIGURATION F-3, F-21, F-29
- EAS CRAWL AND NOTIFY F-3, F-22, F-29
- EAS Upgrade F-1
- Edit Encoding 1-47, 4-5
- Ethernet Cabling 3-10
- Ethernet Interconnection 3-10
- Extending a U-NET Configuration 3-6

### F

- Format Logo File 6-3

### G

- Get Encoding 1-45, 4-3
- Get Revision 1-46, 4-4
- Get System Info 1-46, 4-4
- Get Version 1-46, 4-4
- GPI
  - Sage setup F-7, F-26

---

## H

Hardware Requirements 1-4  
High Definition Video 1-8  
hub  
    U-Net 3-6

## I

Installation  
    PC Prep 1-12  
Installation Routine 1-11  
Introduction 1-1

## J

Java™ Removal A-6

## K

Keyboard Control Commands  
    system logging 5-3

## L

LCD  
    using, on the MCP-2020 panel E-3  
Locks Clear 1-47, 4-5  
Locks Display 1-47, 4-5  
Log Analyzer 5-17  
Log Server 5-3  
Log Server Name  
    customizing 5-6  
Logging Results 5-7  
Logo Generation 6-1

## M

Macro Setup  
    Dasdec EAS net F-31  
    Sage Models F-6  
    Sage models F-25  
    TFT and DASDEC models F-5  
    TFT and Dasdec models F-24  
MANUAL ALERT  
    trigger enable (from MCP-2020 panel) F-34  
MANUAL CONFIGURATION  
    MC-400 EAS Setup F-33  
Manual Configuration  
    MC-2020 upgrade F-8  
Master Control Keywords 5-11  
MC-2020 1-5  
MC-400 EAS Setup F-20  
MX ports 3-8  
MX-Bus 1-5

    communication with a UTAH-300 matrix 3-8  
MX-Bus Interconnection 3-8

## N

Net Verification 1-45, 4-3  
Network Configurations  
    Ethernet 3-13  
NFS Mount 1-46, 4-4

## P

PC Address Identification 2-4  
PC Prep 1-9  
pinouts  
    U-Net cable connection 3-2  
Problem  
    two buttons pressed simultaneously 5-20  
Program Installation 1-1  
Program Removal A-1, A-2

## R

release-logogen  
    directory 6-2  
RMS software 3-10  
Router Controller Keywords 5-13  
Router Load 1-47, 4-5  
Router Save 1-47, 4-5  
Routers 1-5  
Routing Switcher Basics 1-6

## S

SAGE EAS SETUP  
    MC-400 F-34  
Sample EAS Auto Action F-14, F-38  
Sample EAS Display Configuration for Sage F-18, F-41  
Sample EAS Display Configuration for TFT F-16, F-39  
Sample SAGE Macro  
    GPI Section config F-37  
Sample SAGE Macro and GPI Section Config F-13  
Sample Serial Port Setup  
    MC2020 interface to TFT or Sage F-15  
    MC-400 interface to TFT or Sage F-39  
Sample TFT Macro F-12, F-36  
Save Encoding 1-46, 4-4  
Save System Info 1-48, 4-6  
SC-4 connections 3-8  
SC-4 Test Utility Commands C-2  
Serial

---

---

- connection E-3
- SERIAL PORT SETUP F-3, F-22
- signal level
  - definition 1-8
- SqueezeMAX Timing E-4
- Stand-alone Crossover
  - Ethernet Configuration 3-10
- star configuration of SCP panels via U-Net 3-5
- straight-through
  - Ethernet wiring 3-12
- straight-through cable
  - for connecting to an Ethernet hub 3-11
- supported products 1-3
- switching matrix 1-6
- System Logging 5-2

## **T**

- TAS Protocol Notes
  - automation 5-14
- Telnet
  - connection E-3
- Telnet Connection 1-46, 4-4
- TFT EAS SETUP
  - MC-400 F-34
- Tieline Clear 1-47, 4-5
- Tieline Display 1-47, 4-5
- Timed Video E-2
- Timing E-1

## **U**

- UCP Version Upgrade G-1
- U-NET 1-5
- U-NET Cable Requirement 3-2
- U-NET Cable Topologies 3-3
- U-Net hub 3-6
- U-NET Interconnection 3-2
- Un-timed video E-2
- Upgrade Procedure G-2
- Utah Masters to Sage
  - wiring diagram F-35
- Utah MC-2020 to Sage
  - wiring diagram F-11